

RACE SIGNALS

The meanings of visual and sound signals are stated below. An arrow pointing up or down ($\uparrow \downarrow$) means that a visual signal is displayed or removed. A dot (\bullet) means a sound; five short dashes ($- - - - -$) mean repetitive sounds; a long dash ($-$) means a long sound. When a visual signal is displayed over a class flag, the signal applies only to that class.

Postponement Signals

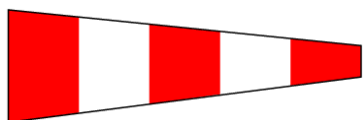

$\uparrow \bullet \bullet \downarrow \bullet$

AP Races not started are *postponed*. The warning signal will be made 1 minute after removal unless at that time the race is *postponed* again or *abandoned*.

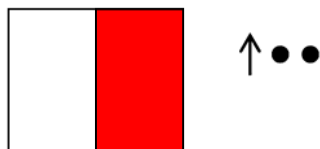
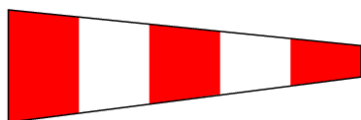

$\uparrow \bullet \bullet$

AP over H Races not started are *postponed*. Further signals ashore.

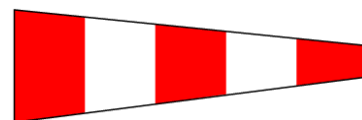

$\uparrow \bullet \bullet$

AP over A Races not started are *postponed*. No more racing today.

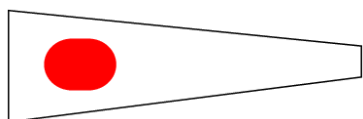

Pennant 1 $\uparrow \bullet \bullet \downarrow \bullet$

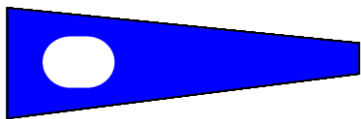

Pennant 2 $\uparrow \bullet \bullet \downarrow \bullet$

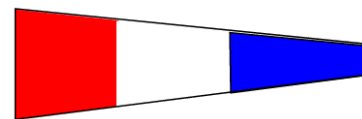

Pennant 3 $\uparrow \bullet \bullet \downarrow \bullet$

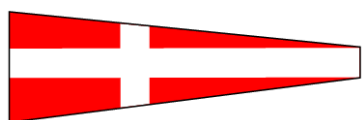

Pennant 4 $\uparrow \bullet \bullet \downarrow \bullet$

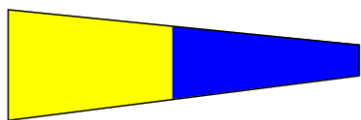

Pennant 5 $\uparrow \bullet \bullet \downarrow \bullet$



Pennant 6 $\uparrow \bullet \bullet \downarrow \bullet$

AP over a numeral pennant 1–6 *Postponement* of 1–6 hours from the scheduled starting time.

Abandonment Signals



$\uparrow \bullet \bullet \bullet \downarrow \bullet$

N All races that have started are *abandoned*. Return to the starting area. The warning signal will be made 1 minute after removal unless at that time the race is *abandoned* again or *postponed*.

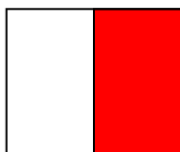

$\uparrow \bullet \bullet \bullet$

N over H All races are *abandoned*. Further signals ashore.

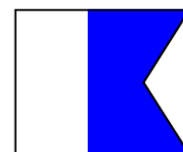
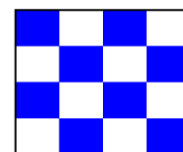

$\uparrow \bullet \bullet \bullet$

N over A All races are *abandoned*. No more racing today.

Preparatory Signals



↑● ↓—

P Preparatory signal.

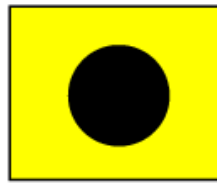

↑● ↓—

I Rule 30.1 is in effect.



↑● ↓—

Black flag. Rule 30.3 is in effect.

Recall Signals



↑●

X Individual recall.

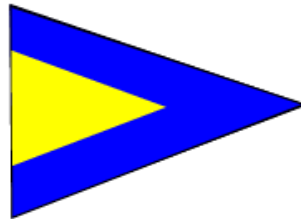

↑●● ↓●

First Substitute General recall. The warning signal will be made 1 minute after removal.

Shortened Course

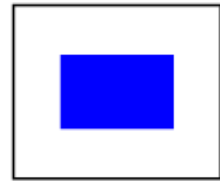

↑●●

S The course has been shortened. Rule 32.2 is in effect.

Changing the Next Leg

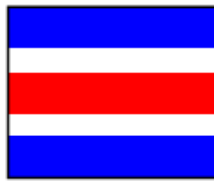

C The position of the next *mark* has been changed:

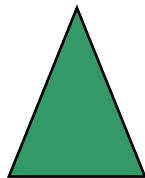

to starboard;



to port;

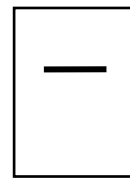

to decrease the length of the leg;

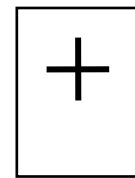

to increase the length of the leg.

Other Signals



↑●

L Ashore: A notice to competitors has been posted.
Afloat: Come within hail or follow this boat.



M The object displaying this signal replaces a missing *mark*.



↑●

Y Wear a personal flotation device.



(no sound)

Blue flag or shape. This race committee boat is in position at the finishing line.

**THE
RACING RULES
OF
SAILING**

for 2009–2012

**EXPERIMENTAL
KITEBOARDING
COMPETITION RULES**

for 2009–2012

**International Sailing Federation
International Kiteboarding Association**

CONTENTS

	Race Signals	<i>Inside front cover</i>
	Introduction	5
	Definitions	7
	Basic Principle	11
	Kiteboarding Competition	11
Part 1	Fundamental Rules	12
Part 2	When Boards Meet	14
Part 3	Conduct of a Race	22
Part 4	Other Requirements When Racing	33
Part 5	Protests, Redress, Hearings, Misconduct and Appeals	37
Part 6	Entry and Qualification	48
Part 7	Race Organization	50
	Appendices	
A	Scoring	54
F	Procedures for Appeals and Requests	60
G	Identification on Sails	62
H	Weighing Clothing and Equipment	67
J	Notice of Race and Sailing Instructions	68
K	Notice of Race Guide	73
L	Sailing Instructions Guide	74
M	Recommendations for Protest Committees	75
N	International Juries	75
	Protest Form	76

INTRODUCTION

The Experimental Kiteboarding Competition Rules for 2009-2012 has been created for use at kiteboarding events as a convenient book on the base of the *Windsurfing Competition Rules for 2009-2012* and *Appendix BB* of the *Racing Rules of Sailing for 2009-2012*. The rules in it are identical to the corresponding rules in *The Windsurfing Competition Rules for 2009-2012* and *Racing Rules of Sailing for 2009-2012*. However, each rule in *Appendix BB* in the general rules has been inserted in this book at the appropriate place, followed by its rule number in *Appendix BB* brackets. For example, rule BB16.3 in the general rules is shown as rule 16.3 in this book and is followed by **[B3.2(b)]**. Each new experimental rule in *Appendix BB* for kiteboarding in the general rules has been inserted in this book at the appropriate place, followed by its experimental rule number in brackets. For example, rule BB13.2 in the general rules is shown as rule 13.2 in this book and is followed by **[BB13.2]**. *Rules shown in red are rules for kiteboarding that differ from the rules for windsurfing in Appendix B or from the rules for sailboats in Sections 1 – 7. These kiteboarding rules are evolving. Organizing authorities are urged to download and use the most recent version. The ISAF Racing Rules Committee and the ISAF Windsurfing Committee would appreciate receiving suggestions for improving these kiteboarding rules.*

Revision The racing rules are revised and published every four years by the International Sailing Federation (ISAF), the international authority for the sport. This edition becomes effective on 1 January 2009. Marginal markings indicate important changes to Parts 1–7 and the Definitions of the 2005–2008 edition. No changes are contemplated before 2013, but any changes determined to be urgent before then will be announced through national authorities and posted on the ISAF website (www.sailing.org) and IKA website IKA website (www.international.kiteboarding.org).

ISAF Codes The ISAF Eligibility, Advertising, Anti-Doping and Sailor Classification Codes (Regulations 19, 20, 21 and 22) are referred to in the definition *Rule* but are not included in this book because they can be changed at any time. The most recent versions of the codes are available on the ISAF website.

Cases and Calls The ISAF publishes interpretations of the racing rules in *The Case Book for 2009–2012* and recognizes them as authoritative interpretations and explanations of the rules. These publications are available on the ISAF website.

Terminology A term used in the sense stated in the Definitions is printed in italics or, in preambles, in bold italics (for example, *racing* and *racing*). ‘Kiteboard’ means a kiteboard and the competitor on board; when a kiteboard meets a boat, it means ‘boat’ as appropriate. ‘Racing rule’ means a rule in *The Racing Rules of Sailing*. ‘Race committee’ includes any person or committee performing a race committee function. A ‘change’ to a *rule* includes an addition to it or deletion of all or part of it. ‘National authority’ means an ISAF member national authority. Other words and terms are used in the sense ordinarily understood in nautical or general use.

Appendices When the rules of an appendix apply, they take precedence over any conflicting rules in Parts 1–7 and the Definitions. Each appendix is identified by a letter. A reference to a rule in an appendix will contain the letter and the rule number (for example, ‘rule A1’). There is no Appendix I or O and Appendices C, D, E and P are not applicable to the kiteboarding. Appendix A is part of the Experimental Kiteboarding Competition Rules and the other Appendices can be used from the Windsurfing Competition rulebook.

Changes to the Rules The prescriptions of a national authority, class rules or the sailing instructions may change a racing rule only as permitted in rule 86.

Changes to National Authority Prescriptions A national authority may restrict changes to its prescriptions as provided in rule 88.2.

DEFINITIONS

A term used as stated below is shown in italic type or, in preambles, in bold italic type.

Abandon A race that a race committee or protest committee *abandons* is void but may be resailed.

About to Round or Pass [B1.1] A kiteboard is *about to round or pass* a mark when her *proper course* is to begin to manoeuvre to round or pass it.

Beach Start [B1.1] When the starting line is on the beach, or so close to the beach that the competitor must stand in the water to *start*, the start is a *beach start*.

Capsized [BB1.1] A kiteboard is *capsized* when her kite is in the water, her lines are tangled, or the competitor has lost control or has accidentally become disconnected from his kiteboard.

Clear Astern and Clear Ahead; Overlap One kiteboard is *clear astern* of another when her hull and equipment in normal position are behind a line abeam from the aftermost point of the other kiteboard's hull and equipment in normal position. The other kiteboard is *clear ahead*. They *overlap* when neither is *clear astern*. However, they also *overlap* when a kiteboard between them *overlaps* both. These terms always apply to kiteboards on the same *tack*. They do not apply to kiteboards on opposite *tacks* unless rule 18 applies or both kiteboards are sailing more than ninety degrees from the true wind.

Fetching A kiteboard is *fetching* a mark when she is in a position to pass to windward of it and leave it on the required side without changing *tack*.

Finish [BB1.1] A kiteboard *finishes* when any part of her hull or competitor crosses the finishing line in the direction of the course from the last *mark*, either for the first time or after correcting an error made at the finishing line under rule 28.1.

Interested Party A person who may gain or lose as a result of a protest committee's decision, or who has a close personal interest in the decision.

Jumping [BB1.1] A kiteboard is *jumping* when her hull and the competitor are clear of the water.

Keep Clear One kiteboard *keeps clear* of another if the other can sail her course with no need to take avoiding action and, when the kiteboards are *overlapped* on the same *tack*, if the *leeward* kiteboard can change course in both directions without immediately making contact with the *windward* kiteboard.

Leeward and Windward [BB1.1] A board's *leeward* side is the side that is or, when she is head to wind, was away from the wind. However, when sailing by the lee or directly downwind, her *leeward* side is the side on which her kite lies. The other side is her *windward* side. When two boards on the same *tack overlap*, the one **whose hull** is on the *leeward* side of the **other's hull** is the *leeward* kiteboard. The other is the *windward* kiteboard.

Mark An object the sailing instructions require a kiteboard to leave on a specified side and a race committee boat surrounded by navigable water from which the starting or finishing line extends. An anchor line or an object attached temporarily or accidentally to a *mark* is not part of it.

Mark-Room *Room* for a kiteboard to sail to the *mark*, and then *room* to sail her *proper course* while at the *mark*. However, *mark-room* does not include *room* to tack unless the kiteboard is *overlapped* to *windward* and on the inside of the kiteboard required to give *mark-room*.

Obstruction [BB1.1] An object that a kiteboard could not pass without changing course substantially, if she was sailing directly towards it and **three** lengths of her hull from it. An object that can be safely passed on only one side and an area so designated by the sailing instructions are also *obstructions*. However, a kiteboard *racing* is not an *obstruction* to other kiteboards unless they are required to *keep clear* of her, give her *room* or *mark-room* or, if rule 22 applies, avoid her. A vessel under way, including a kiteboard *racing*, is never a continuing *obstruction*.

Overlap See *Clear Astern and Clear Ahead; Overlap*.

Overtaking [B1.2] A kiteboard is *overtaking* from the moment she gains an *overlap* from *clear astern* until the moment she is *clear ahead* of the *overtaken* kiteboard.

Party A *party* to a hearing: a protestor; a protestee; a kiteboard requesting redress; a kiteboard or a competitor that may be penalized under rule 69.1; a race committee or an organizing authority in a hearing under rule 62.1(a).

Postpone A *postponed* race is delayed before its scheduled start but may be started or *abandoned* later.

DEFINITIONS

Proper Course A course a kiteboard would sail to *finish* as soon as possible in the absence of the other kiteboards referred to in the rule using the term. A kiteboard has no *proper course* before her starting signal.

Protest An allegation made under rule 61.2 by a kiteboard, a race committee or a protest committee that a kiteboard has broken a *rule*.

Racing A kiteboard is *racing* from her preparatory signal until she *finishes* and clears the finishing line and *marks* or retires, or until the race committee signals a general recall, *postponement* or *abandonment*.

Room The space a kiteboard needs in the existing conditions while manoeuvring promptly in a seamanlike way.

- Rule**
- (a) The rules in this book, including the Definitions, Race Signals, Introduction, preambles and the rules of relevant appendices, but not titles;
 - (b) ISAF Regulation 19, Eligibility Code; Regulation 20, Advertising Code; Regulation 21, Anti-Doping Code; and Regulation 22, Sailor Classification Code;
 - (c) the prescriptions of the national authority, unless they are changed by the sailing instructions in compliance with the national authority's prescription, if any, to rule 88;
 - (d) the class rules (for a kiteboard racing under a handicap or rating system, the rules of that system are 'class rules');
 - (e) the notice of race;
 - (f) the sailing instructions; and
 - (g) any other documents that govern the event.

Start [BB1.1] A kiteboard *starts* when, **her hull and the competitor** having been entirely on the pre-start side of the starting line at or after her starting signal, and having complied with rule 30.1 if it applies, any part of her hull, or **the competitor** crosses the starting line in the direction of the first *mark*.

Tack, Starboard or Port [BB1.1] A board is on the *tack, starboard* or *port*, corresponding to the competitor's hand that would be forward if the competitor were in standard riding position (riding heel side with both hands on the control bar). A kiteboard is on *starboard tack*, when the competitor's right hand would be forward and is on the *port tack* when the competitor's left hand would be forward.

Windward See *Leeward and Windward*.

Zone Not used.

The following definitions apply only to expression competition [B1.2]:

Coming In and Going Out A board sailing in the same direction as the incoming surf is *coming in*. A board sailing in the direction opposite to the incoming surf is *going out*.

Jumping A board is *jumping* when she takes off at the top of a wave while *going out*.

Overtaking A board is *overtaking* from the moment she gains an *overlap* from *clear astern* until the moment she is *clear ahead* of the *overtaken* board.

Possession The first board sailing shoreward immediately in front of a wave has *possession* of that wave. However, when it is impossible to determine which board is first the *windward* board has *possession*.

Recovering A board is *recovering* from the time her sail or, when water-starting, the competitor is out of the water until she has steerage way.

Surfing A board is *surfing* when she is on or immediately in front of a wave while *coming in*.

Transition A board changing *tacks*, or taking off while *coming in*, or one that is not *surfing*, *jumping*, *capsized* or *recovering* is in *transition*.

BASIC PRINCIPLE

SPORTSMANSHIP AND THE RULES

Competitors in the sport of sailing are governed by a body of *rules* that they are expected to follow and enforce. A fundamental principle of sportsmanship is that when competitors break a *rule* they will promptly take a penalty, which may be to retire.

KITEBOARDING COMPETITION

Kiteboarding competition shall be sailed under Appendix B of The Racing Rules of Sailing as changed by Appendix BB.

The term 'boat' elsewhere in the racing rules means 'kiteboard' or 'boat' as appropriate. A kiteboarding event can include one or more of the following disciplines or their formats:

Discipline	Formats
Racing	Course racing; Slalom; Marathon; <i>Downwind Racing; Boarder X</i>
Expression	Wave performance; Freestyle; <i>Wakestyle; Hang Time; High Jump; Kite Loop; Sliders</i>
Speed	<i>Offshore Speed Courses; Speed Crossings</i>

In expression competition a kiteboard's performance is judged on skill and variety rather than speed and is organized using elimination series. Either wave performance or freestyle competition is organized, depending on the wave conditions at the venue. In speed competition, a 'round' consists of one or more speed runs in which the kiteboards take turns sailing the course at intervals. In the racing discipline a marathon race is a race scheduled to last more than one hour.

In racing or expression competition, 'heat' means one elimination contest, a 'round' consists of one or more heats, and an elimination series consists of one or more rounds.

PART 1

FUNDAMENTAL RULES

1 SAFETY

1.1 Helping Those in Danger

A kiteboard or competitor shall give all possible help to any person or vessel in danger.

1.2 Life-Saving Equipment and Personal Flotation Devices

A kiteboard shall carry adequate life-saving equipment according to her class rules. Each competitor is individually responsible for wearing a personal flotation device adequate for the conditions.

2 FAIR SAILING

A kiteboard and her owner shall compete in compliance with recognized principles of sportsmanship and fair play. A kiteboard may be penalized under this rule only if it is clearly established that these principles have been violated. A disqualification under this rule shall not be excluded from the kiteboard's series score.

3 ACCEPTANCE OF THE RULES

By participating in a race conducted under these racing rules, each competitor and kiteboard owner agrees

- (a) to be governed by the *rules*;
- (b) to accept the penalties imposed and other action taken under the *rules*, subject to the appeal and review procedures provided in them, as the final determination of any matter arising under the *rules*; and
- (c) with respect to any such determination, not to resort to any court of law or tribunal.

4 DECISION TO RACE

The responsibility for a kiteboard's decision to participate in a race or to continue *racing* is hers alone.

5 ANTI-DOPING

A competitor shall comply with the World Anti-Doping Code, the rules of the World Anti-Doping Agency, and ISAF Regulation 21, Anti-Doping Code. An alleged or actual breach of this rule shall be dealt with under Regulation 21. It shall not be grounds for a *protest* and rule 63.1 does not apply.

PART 2

WHEN KITEBOARDS MEET

*The rules of Part 2 apply between kiteboards that are sailing in or near the racing area and intend to **race**, are **racing**, or have been **racing**. However, a kiteboard not **racing** shall not be penalized for breaking one of these rules, except rule 23.1 or 23.3. [B3.2(a)]*

When a kiteboard sailing under these rules meets a vessel that is not, she shall comply with the International Regulations for Preventing Collisions at Sea (IRPCAS) or government right-of-way rules. If the sailing instructions so state, the rules of Part 2 are replaced by the right-of-way rules of the IRPCAS or by government right-of-way rules.

SECTION A

RIGHT OF WAY

*A kiteboard has right of way when another kiteboard is required to **keep clear** of her. However, some rules in Sections B, C and D limit the actions of a right-of-way kiteboard.*

10 ON OPPOSITE TACKS

*When kiteboards are on opposite *tacks*, a *port-tack* kiteboard shall *keep clear* of a *starboard-tack* kiteboard.*

11 ON THE SAME TACK, OVERLAPPED

*When kiteboards are on the same *tack* and *overlapped*, a *windward* kiteboard shall *keep clear* of a *leeward* kiteboard.*

12 ON THE SAME TACK, NOT OVERLAPPED

*When kiteboards are on the same *tack* and not *overlapped*, a kiteboard *clear astern* shall *keep clear* of a kiteboard *clear ahead*.*

13 EXCEPTIONS TO RULES 10, 11 AND 12 [BB3.2(b)]

13.1 *When a kiteboard changes *tack* on an upwind leg, she shall *keep clear* of other kiteboards until she is on a close-hauled course. Dur-*

ing that time rules 10, 11 and 12 do not apply. If two kiteboards are subject to this rule at the same time, the one on the other's port side or the one astern shall *keep clear*.

13.2 When sailing downwind, a kiteboard that is *looping* her kite shall *keep clear* of one that is not.

13.3 If two boards converge while sailing downwind and it is not possible under rule 10, 11 or 12 to determine which one has right of way, the one on the other's starboard side or the one astern shall *keep clear*.

SECTION B

GENERAL LIMITATIONS

14 AVOIDING CONTACT

A kiteboard shall avoid contact with another kiteboard if reasonably possible. However, a right-of-way kiteboard or one entitled to *room* or *mark-room*

- (a) need not act to avoid contact until it is clear that the other kiteboard is not *keeping clear* or giving *room* or *mark-room*, and
- (b) shall not be penalized under this rule unless there is contact that causes damage or injury.

15 ACQUIRING RIGHT OF WAY

When a kiteboard acquires right of way, she shall initially give the other kiteboard *room* to *keep clear*, unless she acquires right of way because of the other kiteboard's actions.

16 CHANGING COURSE OR KITE POSITION [BB3.2(c)]

16.1 When a right-of-way kiteboard changes course or the position of her kite, she shall give the other kiteboard *room* to *keep clear*.

16.2 On a beat to windward, when it becomes clear to a *starboard-tack* kiteboard that a *port-tack* kiteboard is *keeping clear* by sailing to pass astern of her and there is risk of contact, the *starboard-tack* kiteboard shall, if reasonably possible, keep her kite high enough to allow the *port-tack* kiteboard to pass close astern of her hull.

16.3 In slalom racing, a right-of-way kiteboard shall not change her course or the position of her kite during the last 30 seconds before

her starting signal if as a result the other kiteboard would have to take immediate action to avoid contact.

17 Deleted. [B2.6]

SECTION C AT MARKS AND OBSTRUCTIONS

*Section C rules do not apply at a starting **mark** surrounded by navigable water or at its anchor line from the time kiteboards are approaching them to **start** until they have passed them. When rule 20 applies, rules 18 and 19 do not.*

18 MARK-ROOM

18.1 When Rule 18 Applies [B3.1(a)]

Rule 18 applies between kiteboards when they are required to leave a *mark* on the same side and at least one of them is *about to round or pass* the mark until they have passed it. However, it does not apply

- (a) between kiteboards on opposite *tacks* on a beat to windward,
- (b) between kiteboards on opposite *tacks* when the *proper course* at the *mark* for one but not both of them is to tack,
- (c) between a kiteboard approaching a *mark* and one leaving it, or
- (d) if the *mark* is a continuing *obstruction*, in which case rule 19 applies.

18.2 Giving Mark-Room

- (a) When kiteboards are *overlapped* the outside kiteboard shall give the inside kiteboard *mark-room*, unless rule 18.2(b) applies.
- (b) If kiteboards are *overlapped* when the first of them is *about to round or pass* the *mark*, the outside kiteboard at that moment shall thereafter give the inside kiteboard *mark-room*. If a kiteboard is *clear ahead* when she is *about to round or pass* the *mark*, the kiteboard *clear astern* at that moment shall thereafter give her *mark-room*. [B3.1(b)]

- (c) When a kiteboard is required to give *mark-room* by rule 18.2(b), she shall continue to do so even if later an *overlap* is broken or a new *overlap* begins. [B3.1(c)]
- (d) If there is reasonable doubt that a kiteboard obtained or broke an *overlap* in time, it shall be presumed that she did not.
- (e) If a kiteboard obtained an inside *overlap* from *clear astern* and, from the time the *overlap* began, the outside kiteboard has been unable to give *mark-room*, she is not required to give it.

18.3 Deleted. [B2.6]

18.4 Gybing [B3.1(d)]

When an inside *overlapped* right-of-way kiteboard must **change tack** or bear away at a *mark* to sail her *proper course*, until she **changes tacks** or bear away she shall sail no farther from the *mark* than needed to sail that course. Rule 18.4 does not apply at a gate *mark*.

18.5 Exoneration

When a kiteboard is taking *mark-room* to which she is entitled, she shall be exonerated

- (a) if, as a result of the other kiteboard failing to give her *mark-room*, she breaks a rule of Section A, or
- (b) if, by rounding the *mark* on her *proper course*, she breaks a rule of Section A or rule 15 or 16.

19 ROOM TO PASS AN OBSTRUCTION

19.1 When Rule 19 Applies

Rule 19 applies between kiteboards at an *obstruction* except when it is also a *mark* the kiteboards are required to leave on the same side. However, at a continuing *obstruction*, rule 19 always applies and rule 18 does not.

19.2 Giving Room at an Obstruction

- (a) A right-of-way kiteboard may choose to pass an *obstruction* on either side.
- (b) When kiteboards are *overlapped*, the outside kiteboard shall give the inside kiteboard *room* between her and the *obstruction*, unless she has been unable to do so from the time the *overlap* began.

- (c) While kiteboards are passing a continuing *obstruction*, if a kiteboard that was *clear astern* and required to *keep clear* becomes *overlapped* between the other kiteboard and the *obstruction* and, at the moment the *overlap* begins, there is not *room* for her to pass between them, she is not entitled to *room* under rule 19.2(b). While the kiteboards remain *overlapped*, she shall *keep clear* and rules 10 and 11 do not apply.

20 ROOM TO TACK AT AN OBSTRUCTION

20.1 Hailing and Responding

When approaching an *obstruction*, a kiteboard sailing close-hauled or above may hail for *room* to tack and avoid another kiteboard on the same *tack*. After a kiteboard hails,

- (a) she shall give the hailed kiteboard time to respond;
- (b) the hailed kiteboard shall respond either by tacking as soon as possible, or by immediately replying ‘You tack’ and then giving the hailing kiteboard *room* to tack and avoid her; and
- (c) when the hailed kiteboard responds, the hailing kiteboard shall tack as soon as possible.

20.2 Exoneration

When a kiteboard is taking *room* to which she is entitled under rule 20.1(b), she shall be exonerated if she breaks a rule of Section A or rule 15 or 16.

20.3 When Not to Hail

A kiteboard shall not hail unless safety requires her to make a substantial course change to avoid the *obstruction*. Also, she shall not hail if the *obstruction* is a *mark* that the hailed kiteboard is *fetching*.

SECTION D

OTHER RULES

When rule 21 or 22 applies between two kiteboards, Section A rules do not.

21 STARTING ERRORS AND OTHER REQUIREMENTS [BB3.2(e)]

21.1 A kiteboard sailing towards the pre-start side of the starting line or one of its extensions after her starting signal to *start* or to comply with rule 30.1 shall *keep clear* of a kiteboard not doing so until she is completely on the pre-start side.

21.2 When approaching the starting line to *start*, a kiteboard shall have her kite out of the water and in a normal position, except when accidentally *capsized*. [B3.1(f)]

21.3 During the last minute before her starting signal, a kiteboard that significantly slows down or stops, and is no longer making material forward progress, shall *keep clear* of one that has not.

21.4 A kiteboard that is *jumping* shall *keep clear* of a kiteboard that is not.

22 CAPSIZED, ANCHORED OR AGROUND; RESCUING

22.1 If possible, a kiteboard shall avoid a kiteboard that is *capsized* or has not regained control after *capsizing*, is anchored or aground, or is trying to help a person or vessel in danger.

22.2 A *capsized* kiteboard shall not take an action that hinders another kiteboard. [B3.2(c)]

23 INTERFERING WITH ANOTHER BOARD

23.1 If reasonably possible, a kiteboard not *racing* shall not interfere with a kiteboard that is *racing*. After *finishing*, a kiteboard shall immediately clear the finishing line and *marks* and avoid kiteboards still *racing*. [B3.2(d)]

23.2 Except when sailing her *proper course*, a kiteboard shall not interfere with a kiteboard sailing on another leg.

23.3 A kiteboard shall not sail in the course area defined in the sailing instructions when races are taking place except in her own race. [B3.2(e)]

SECTION E

RULES FOR EXPRESSION AND SPEED COMPETITION

24 RULES FOR EXPRESSION AND SPEED COMPETITION

24.1 **Right-of-Way Rules for Expression Competitions [B4.1]**

These rules replace all rules of Part 2 – Sections A, B, C and D.

(a) COMING IN AND GOING OUT

A kiteboard *coming in* shall *keep clear* of a kiteboard *going out*. When two kiteboards are *going out* or *coming in* while on the same wave, or when neither is *going out* or *coming in*, a kiteboard on *port tack* shall *keep clear* of the one on *starboard tack*.

(b) KITEBOARDS ON THE SAME WAVE, COMING IN

When two or more kiteboards are on a wave *coming in*, a kiteboard that does not have *possession* shall *keep clear*.

(c) CLEAR ASTERN, CLEAR AHEAD AND OVERTAKING

A kiteboard *clear astern* and not on a wave shall *keep clear* of a kiteboard *clear ahead*. An *overtaking* kiteboard that is not on a wave shall *keep clear*.

(d) TRANSITION

A kiteboard in *transition* shall *keep clear* of one that is not. When two kiteboards are in *transition* at the same time, the one on the other's port side or the one astern shall *keep clear*.

24.2 General Rules for Speed Competitions [B6.1]

All other rules of Part 2 are replaced by relevant parts of this rule.

(a) BEACH AND WATER STARTING

A kiteboard shall not *beach start* or *water start* on the course or in the starting area, except to sail off the course to avoid kiteboards that are *starting* or *racing*.

(b) LEAVING THE COURSE AREA

A kiteboard leaving the course area shall *keep clear* of boards *racing*.

(c) COURSE CONTROL

When the race committee points an orange flag at a kiteboard, she is penalized and the run shall not count.

(d) RETURNING TO THE STARTING AREA

A kiteboard returning to the starting area shall *keep clear* of the course.

(e) RUN; ROUND

The maximum number of runs to be made by each kiteboard in a round shall be announced by the race committee not later than 15 minutes before the starting signal for the first round.

(f) DURATION OF A ROUND

The duration of a round shall be announced by the race committee no later than 15 minutes before the starting signal for the next round.

(g) CONDITIONS FOR ESTABLISHING A RECORD

The minimum distance for a world record is 500 metres. Other records may be established over shorter distances. The course shall be defined by posts and transits ashore or by buoys afloat. Transits shall not converge.

PART 3

CONDUCT OF A RACE

25 NOTICE OF RACE, SAILING INSTRUCTIONS AND SIGNALS

The notice of race and sailing instructions shall be made available to each kiteboard before a race begins. The meanings of the visual and sound signals stated in Race Signals shall not be changed except under rule 86.1(b). The meanings of any other signals that may be used shall be stated in the sailing instructions.

26 STARTING SYSTEMS

26.1 Starting Races

The sailing instructions shall specify one of these starting systems.

(a) SYSTEM 1

Races shall be started by using the following signals. Times shall be taken from the visual signals; the absence of a sound signal shall be disregarded.

<i>Signal</i>	<i>Flag and sound</i>	<i>Minutes before starting signal</i>
Warning	Class flag; 1 sound	5*
Preparatory	P, I or black flag; 1 sound	4
One-minute	Preparatory flag removed; 1 long sound	1
Starting	Class flag removed; 1 sound	0

*or as stated in the sailing instructions

The warning signal for each succeeding class shall be made with or after the starting signal of the preceding class.

(b) SYSTEM 2 [B3.3(b)]

Races shall be started by using the following signals. Times shall be taken from the visual signals; the absence of a sound signal shall be disregarded.

<i>Signal</i>	<i>Flag and sound</i>	<i>Minutes before starting signal</i>
Attention	Class flag or heat number	3
Warning	Red flag; Attention signal removed; 1 sound	2
Preparatory	Yellow flag; ; Red flag removed; 1 sound	1
	Yellow flag removed	1/2
Starting	Green flag; 1 sound	0

(c) SYSTEM 3 (FOR BEACH STARTS) [B3.3(c)]

- (1) Before her start each kiteboard in a heat or class shall draw a number for her station on the starting line. The stations shall be numbered so that station 1 is the most windward one.
- (2) After kiteboards have been called to take their positions, the race committee shall make the preparatory signal by displaying a red flag with one sound. The starting signal shall be made, at any time after the preparatory signal, by removing the red flag with one sound.
- (3) After the starting signal each kiteboard shall take the shortest route from her starting station to her kiteboarding position in the water (with both of the competitor's feet on the kiteboard).

26.2 Starting and Ending Heats for Expression Competition [B4.2]

Heats shall be started and ended by using the following signals:

(a) STARTING A HEAT

Each flag shall be removed when the next flag is displayed.

<i>Signal</i>	<i>Flag and sound</i>	<i>Minutes before starting signal</i>
Attention	Heat number	3
Warning	Red flag; 1 sound	2
Preparatory	Yellow flag; 1 sound	1
Starting	Green flag; 1 sound	0

(b) ENDING A HEAT

<i>Signal</i>	<i>Flag and sound</i>	<i>Minutes before ending signal</i>
End warning	Green flag removed; 1 sound	1
Ending	Red flag; 1 sound	0

26.3 Starting System for Speed Competition

Rounds shall be started and ended by using the following signals. Each flag shall be removed when the next flag is displayed.

(a) STARTING A ROUND [**B6.2**]

<i>Signal</i>	<i>Flag</i>	<i>Meaning</i>
Stand-by	Red flag	Course closed
Course closed	AP and red flag	Course closed; will open shortly
Preparatory	Yellow flag	Course will open in 5 minutes
Starting	Green flag	Course is open

(b) ENDING A ROUND [**B6.2**]

<i>Signal</i>	<i>Flag</i>	<i>Meaning</i>
End warning	Green and yellow flag	Course will be closed in 5 minutes
Extension	Green flag and L	Current round extended by 15 minutes
Round ended	Red flag and L	A new round will be started shortly

27 OTHER RACE COMMITTEE ACTIONS BEFORE THE STARTING SIGNAL

27.1 No later than the warning signal, the race committee shall signal or otherwise designate the course to be sailed if the sailing instructions have not stated the course, and it may replace one course signal

with another and signal that wearing personal flotation devices is required (display flag Y with one sound).

27.2 No later than the preparatory signal, the race committee may move a starting *mark*.

27.3 Before the starting signal, the race committee may for any reason *postpone* (display flag AP, AP over H, or AP over A, with two sounds) or *abandon* the race (display flag N over H, or N over A, with three sounds).

28 SAILING THE COURSE

28.1 A kiteboard shall *start*, leave each *mark* on the required side in the correct order, and *finish*, so that a string representing her track after *starting* and until *finishing* would when drawn taut

- (a) pass each *mark* on the required side,
- (b) touch each rounding *mark*, and
- (c) pass between the *marks* of a gate from the direction of the previous *mark*.

She may correct any errors to comply with this rule. After *finishing* she need not cross the finishing line completely.

28.2 A kiteboard may leave on either side a *mark* that does not begin, bound or end the leg she is on. However, she shall leave a starting *mark* on the required side when she is approaching the starting line from its pre-start side to *start*.

29 RECALLS

29.1 Individual Recall

When at a kiteboard's starting signal any part of her hull or competitor is on the course side of the starting line or she must comply with rule 30.1, the race committee shall promptly display flag X with one sound. The flag shall be displayed until all such kiteboards are completely on the pre-start side of the starting line or one of its extensions and have complied with rule 30.1 if it applies, but no later than four minutes after the starting signal or one minute before any later starting signal, whichever is earlier. If rule 30.3 applies this rule does not.

29.2 General Recall

When at the starting signal the race committee is unable to identify kiteboards that are on the course side of the starting line or to which rule 30 applies, or there has been an error in the starting procedure, the race committee may signal a general recall (display the First Substitute with two sounds). The warning signal for a new start for the recalled class shall be made one minute after the First Substitute is removed (one sound), and the starts for any succeeding classes shall follow the new start.

29.3 Recall for Races with Elimination [B3.4]

- (a) When at a kiteboard's starting signal for a slalom race or heat any part of her hull or **competitor** is on the course side of the starting line, the race committee shall signal a general recall.
- (b) If the race committee acts under rule 29.3(a) and the kiteboard is identified, she shall be disqualified without a hearing, even if the race or heat is *postponed* or *abandoned*. The race committee shall hail or display her kite number, and she shall leave the course area immediately. If the race or heat is restarted or resailed, she shall not sail in it.
- (c) If a slalom race or heat was completed but was later *abandoned* by the protest committee and if the race or heat is resailed, a kiteboard disqualified under rule 29.3(b) may sail in it.

30 STARTING PENALTIES

30.1 I Flag Rule

If flag I has been displayed, and any part of a hull or **competitor** is on the course side of the starting line or one of its extensions during the last minute before her starting signal, she shall thereafter sail from the course side across an extension to the pre-start side before *starting*.

30.2 Z Flag Rule

If flag Z has been displayed, no part of a hull or **competitor** shall be in the triangle formed by the ends of the starting line and the first *mark* during the last minute before her starting signal. If a kiteboard breaks this rule and is identified, she shall receive, without a hearing, a 20% Scoring Penalty calculated as stated in rule 44.3(c). She shall be penalized even if the race is restarted or resailed, but not if it is

postponed or *abandoned* before the starting signal. If she is similarly identified during a subsequent attempt to start the same race, she shall receive an additional 20% Scoring Penalty.

30.3 Black Flag Rule

If a black flag has been displayed, no part of a hull or **competitor** shall be in the triangle formed by the ends of the starting line and the first *mark* during the last minute before her starting signal. If a kiteboard breaks this rule and is identified, she shall be disqualified without a hearing, even if the race is restarted, or resailed, but not if it is *postponed* or *abandoned* before the starting signal. If a general recall is signalled or the race is *abandoned* after the starting signal, the race committee shall display her kite number before the next warning signal for that race, and if the race is restarted or resailed she shall not sail in it. If she does so, her disqualification shall not be excluded in calculating her series score.

31 TOUCHING A MARK [B2.5]

A kiteboard may touch a *mark* but shall not hold on to it.

32 SHORTENING OR ABANDONING AFTER THE START

32.1 After the starting signal, the race committee may shorten the course (display flag S with two sounds) or *abandon* the race (display flag N, N over H, or N over A, with three sounds), as appropriate,

- (a) because of an error in the starting procedure,
- (b) because of foul weather,
- (c) because of insufficient wind making it unlikely that any board will *finish* within the time limit,
- (d) because a *mark* is missing or out of position, or
- (e) for any other reason directly affecting the safety or fairness of the competition,

or may shorten the course so that other scheduled races can be sailed. However, after one kiteboard has sailed the course and *finished* within the time limit, if any, the race committee shall not *abandon* the race without considering the consequences for all kiteboards in the race or series.

32.2 If the race committee signals a shortened course (displays flag S with two sounds), the finishing line shall be,

- (a) at a rounding *mark*, between the *mark* and a staff displaying flag S;
- (b) at a line kiteboards are required to cross at the end of each lap, that line;
- (c) at a gate, between the gate *marks*.

The shortened course shall be signalled before the first kiteboard crosses the finishing line.

33 CHANGING THE NEXT LEG OF THE COURSE

The race committee may change a leg of the course that begins at a rounding *mark* or at a gate by changing the position of the next *mark* (or the finishing line) and signalling all kiteboards before they begin the leg. The next *mark* need not be in position at that time.

- (a) If the direction of the leg will be changed, the signal shall be the display of flag C with repetitive sounds and either
 - (1) the new compass bearing or
 - (2) a green triangular flag or board for a change to starboard or a red rectangular flag or board for a change to port.
- (b) If the length of the leg will be changed, the signal shall be the display of flag C with repetitive sounds and a ‘-’ if the length will be decreased or a ‘+’ if it will be increased.
- (c) Subsequent legs may be changed without further signalling to maintain the course shape.

34 MARK MISSING

If a *mark* is missing or out of position, the race committee shall, if possible,

- (a) replace it in its correct position or substitute a new one of similar appearance, or
- (b) substitute an object displaying flag M and make repetitive sound signals.

35 TIME LIMIT AND SCORES

If one kiteboard sails the course as required by rule 28.1 and *finishes* within the time limit, if any, all kiteboards that *finish* shall be scored according to their finishing places unless the race is *abandoned*. If no kiteboard *finishes* within the time limit, the race committee shall *abandon* the race.

36 RACES RESTARTED OR RESAILED

If a race is restarted or resailed, a breach of a *rule*, other than rule 29.3(c) or 30.3, in the original race shall not prohibit a kiteboard from competing or, except under rule 29.3(c), 30.3 or 69, cause her to be penalized.

37 EXPRESSION COMPETITION – REGISTRATION OF KITES; COURSE AREA; HEAT DURATION [B4.3]

- (a) Kiteboards shall register with the race committee the colours and other particulars of their kites, or their identification according to another method stated in the sailing instructions, no later than the starting signal for the heat two heats before their own.
- (b) The course area shall be defined in the sailing instructions and posted on the official notice board no later than 10 minutes before the starting signal for the first heat. A kiteboard shall be scored only while sailing in the course area.
- (c) Any change in heat duration shall be announced by the race committee no later than 15 minutes before the starting signal for the first heat in the next round.

38 ELIMINATION SERIES [B5]

Rule 38 applies when an elimination series is organized in which kiteboards compete in heats.

38.1 Elimination Series Procedure

- (a) Competition shall take the form of one or more elimination series. Each of them shall consist of either rounds in a single elimination series where only a number of the best scorers advance, or rounds in a double elimination series where kiteboards have more than one opportunity to advance.
- (b) Kiteboards shall sail one against another in pairs, or in groups determined by the elimination ladder. The selected form of

competition shall not be changed while a round remains uncompleted.

38.2 Seeding and Ranking Lists

- (a) When a seeding or ranking list is used to establish the heats of the first round, places 1–8 (four heats) or 1–16 (eight heats) shall be distributed evenly among the heats.
- (b) For a subsequent elimination series, if any, kiteboards shall be reassigned to new heats according to the ranking in the previous elimination series.
- (c) The organizing authority's seeding decisions are final and are not grounds for a request for redress.

38.3 Heat Schedule

The schedule of heats shall be posted on the official notice board no later than 30 minutes before the starting signal for the first heat.

38.4 Advancement and Byes

- (a) In racing and expression competition, the kiteboards in each heat to advance to the next round shall be announced by the race committee no later than 10 minutes before the starting signal for the first heat. The number advancing may be changed by the protest committee as a result of a redress decision.
- (b) In expression competition, any first-round byes shall be assigned to the highest-seeded kiteboards.
- (c) In wave performance competition, only the winner of each heat shall advance to the next round.
- (d) In freestyle competition, kiteboards shall advance to the next round as follows: from an eight-kiteboard heat, the best four advance, and the winner will sail against the fourth and the second against the third; from a four-kiteboard heat, the best two advance and will sail against each other.

38.5 Finals

- (a) The final shall consist of a maximum of three races. The race committee shall announce the number of races to be sailed in the final no later than 5 minutes before the warning signal for the first final race.

- (b) A runners-up final may be sailed after the final. All kiteboards in the semi-final heats that failed to qualify for the final may compete in it.

39 SPECIAL RULES FOR SPEED COMPETITION

39.1 Penalties [B6.3]

- (a) If a kiteboard fails to comply with a rule or infringes the course area regulations, she may be cautioned and her shirt number shall be posted on a notice board near the finishing line.
- (b) If a kiteboard is cautioned a second time during the same round, she shall be suspended by the race committee from the remainder of the round and her shirt number shall be posted on the official notice board.
- (c) A kiteboard observed in the course area while suspended shall be excluded from the competition without a hearing and none of her previous times or results shall be valid.
- (d) Any breach of the verification rules may result in a suspension from the competition for any period.

39.2 Verification [B6.4]

- (a) An observer appointed by the World Sailing Speed Record Council (WSSRC) shall be present and verify run times and speeds at world record attempts. The race committee shall verify run times and speeds at other record attempts.
- (b) A competitor shall not enter the timing control area or discuss any timing matter directly with the timing organization. Any timing question shall be directed to the race committee.

PART 4

OTHER REQUIREMENTS WHEN RACING

*Part 4 rules apply only to kiteboards **racing**.*

40 PERSONAL FLOTATION DEVICES

When flag Y is displayed with one sound before or with the warning signal, competitors shall wear personal flotation devices, except briefly while changing or adjusting clothing or personal equipment. Wet suits and dry suits are not personal flotation devices.

41 OUTSIDE HELP

41.1 A kiteboard shall not receive help from any outside source, except

- (a) help for an ill or injured crew member;
- (b) after a collision, help from the crew of the other kiteboard to get clear;
- (c) help in the form of information freely available to all kiteboards;
- (d) unsolicited information from a disinterested source, which may be another kiteboard in the same race.
- (e) **another kiteboard, who is also racing, may assist a relaunch.**

[BB4.2(b)]

41.2 Outside Help for Expression Competition

An assistant may provide replacement equipment to a kiteboard or kite but only outside the judging zone. A kiteboard whose assistant fails to keep clear shall be penalized. The penalty shall be at the discretion of the protest committee.

42 PROPULSION [B2.1(a)]

A kiteboard shall be propelled only by the action of the wind on the sail, by the action of the water on the hull and by the unassisted actions of the competitor.

43 COMPETITOR CLOTHING AND EQUIPMENT

- 43.1** (a) Competitors shall not wear or carry clothing or equipment for the purpose of increasing their weight. However, a competitor may wear a drinking container that shall have a capacity of at least one litre and weigh no more than 1,5 kilograms when full. **[B2.1(b)]**
- (b) Furthermore, a competitor's clothing and equipment shall not weigh more than 8 kilograms, excluding a hiking or trapeze harness and clothing (including footwear) worn only below the knee. Class rules or sailing instructions may specify a lower weight or a higher weight up to 10 kilograms. Class rules may include footwear and other clothing worn below the knee within that weight. A hiking or trapeze harness shall have positive buoyancy and shall not weigh more than 2 kilograms, except that class rules may specify a higher weight up to 4 kilograms. Weights shall be determined as required by Appendix H.
- (c) When an equipment inspector or a measurer in charge of weighing clothing and equipment believes a competitor may have broken rule 43.1(a) or 43.1(b) he shall report the matter in writing to the race committee.

43.2 Deleted. **[B2.6]**

44 PENALTIES AT THE TIME OF AN INCIDENT **[BB2.1(c)]**

44.1 Taking a Penalty

A kiteboard may take a Scoring Penalty when she may have broken a rule of Part 2 while *racing*. However, if the kiteboard caused injury or serious damage or gained a significant advantage in the race or series by her breach her penalty shall be to retire.

44.2 Scoring Penalty

- (a) When a kiteboard decides to take a Scoring Penalty, she shall inform the other kiteboard, if possible. She shall complete a scoring adjustment form for each penalty within the time limit for *protests*.
- (b) The race score for a kiteboard that takes a Scoring Penalty shall be the score she would have received without that penalty, made worse by the number of places stated in the sailing instructions. However, she shall not be scored worse than Did Not Finish. When the sailing instructions do not state the number of places, the number shall be the whole number (rounding 0.5 upward) nearest to 20% of the num-

ber of boards entered. The scores of other kiteboards shall not be changed; therefore, two kiteboards may receive the same score.

45 Deleted. [B2.6]

46 **PERSON IN CHARGE**

A kiteboard shall have on board a person in charge designated by the member or organization that entered the kiteboard. See rule 75.

47 **LIMITATIONS ON EQUIPMENT AND CREW**

47.1 A kiteboard shall use only the equipment on board at her preparatory signal, except as stated in rule 41.2. [B2.1(d)]

47.2 Deleted. [B2.6]

47.3 In Speed and Expression competition, competitors may change equipment during the leg or heat.

48 Deleted. [B2.6]

49 Deleted. [B2.6]

50 Deleted. [B2.6]

51 Deleted. [B2.6]

52 Deleted. [B2.6]

53 **SKIN FRICTION**

A kiteboard shall not eject or release a substance, such as a polymer, or have specially textured surfaces that could improve the character of the flow of water inside the boundary layer.

54 Deleted. [B2.6]

PART 5

PROTESTS, REDRESS, HEARINGS, MISCONDUCT AND APPEALS

SECTION A

PROTESTS; REDRESS; RULE 69 ACTION

60 RIGHT TO PROTEST; RIGHT TO REQUEST REDRESS OR RULE 69 ACTION

60.1 A kiteboard may

- (a) protest another kiteboard, but not for an alleged breach of a rule of Part 2 unless she was involved in or saw the incident; or
- (b) request redress.

60.2 A race committee may

- (a) protest a kiteboard, but not as a result of information arising from a request for redress or an invalid *protest*, or from a report from an *interested party* other than the representative of the kiteboard herself;
- (b) request redress for a kiteboard; or
- (c) report to the protest committee requesting action under rule 69.1(a).

However, when the race committee receives a report required by rule 43.1(c) or 78.3, it shall protest the kiteboard.

60.3 A protest committee may

- (a) protest a kiteboard, but not as a result of information arising from a request for redress or an invalid *protest*, or from a report from an *interested party* other than the representative of the kiteboard herself. However, it may protest a kiteboard
 - (1) if it learns of an incident involving her that may have resulted in injury or serious damage, or
 - (2) if during the hearing of a valid *protest* it learns that the kiteboard, although not a *party* to the hearing, was involved in the incident and may have broken a *rule*;

- (b) call a hearing to consider redress; or
- (c) act under rule 69.1(a).

61 PROTEST REQUIREMENTS

61.1 Informing the Protestee [B7.1]

- (a) A kiteboard intending to protest shall inform the other board at the first reasonable opportunity. When her *protest* concerns an incident in the racing area that she is involved in or sees, she shall hail 'Protest'. She shall inform the race committee of her intention to protest immediately after she *finishes* or retires. However,
 - (1) if the other kiteboard is beyond hailing distance, the protesting kiteboard need not hail but she shall inform the other kiteboard at the first reasonable opportunity;
 - (2) Deleted.
 - (3) if the incident results in damage or injury that is obvious to the kiteboards involved and one of them intends to protest, the requirements of this rule do not apply to her, but she shall attempt to inform the other kiteboard within the time limit of rule 61.3.
- (b) A race committee or protest committee intending to protest a board shall inform her as soon as reasonably possible. However, if the *protest* arises from an incident the committee observes in the racing area, it shall inform the kiteboard after the race within the time limit of rule 61.3.
- (c) If the protest committee decides to protest a kiteboard under rule 60.3(a)(2), it shall inform her as soon as reasonably possible, close the current hearing, proceed as required by rules 61.2 and 63, and hear the original and the new *protests* together.

61.2 Protest Contents

- (a) COURSE AND MARATHON RACING

A *protest* shall be in writing and identify

 - (1) the protestor and protestee;
 - (2) the incident, including where and when it occurred;
 - (3) any *rule* the protestor believes was broken; and

(4) the name of the protestor's representative.

However, if requirement (2) is met, requirement (1) may be met at any time before the hearing, and requirements (3) and (4) may be met before or during the hearing.

(b) ELIMINATION SERIES

In an elimination series, *protests* and requests for redress shall be made orally immediately following the heat in which the incident occurred. The protest committee may take evidence in any way it considers appropriate and may communicate its decision orally. [B7.2]

61.3 Protest Time Limit

A *protest* by a kiteboard, or by the race committee or protest committee about an incident the committee observes in the racing area, shall be delivered to the race office within the time limit stated in the sailing instructions. If none is stated, the time limit is two hours after the last kiteboard in the race *finishes*. Other race committee or protest committee *protests* shall be delivered to the race office no later than two hours after the committee receives the relevant information. The protest committee shall extend the time if there is good reason to do so.

62 REDRESS

62.1 A request for redress or a protest committee's decision to consider redress shall be based on a claim or possibility that a kiteboard's score in a race or series has, through no fault of her own, been made significantly worse by

- (a) an improper action or omission of the race committee, protest committee or organizing authority, but not by a protest committee decision when the kiteboard was a *party* to the hearing;
- (b) injury or physical damage because of the action of a kiteboard that was breaking a rule of Part 2 or of a vessel not *racing* that was required to keep clear;
- (c) giving help (except to herself) in compliance with rule 1.1;
- (d) a kiteboard against which a penalty has been imposed under rule 2 or disciplinary action has been taken under rule 69.1(b); or

- (e) a kiteboard that failed to *keep clear* and caused *capsize* of the other kiteboard. [B7.3]

62.2 The request shall be in writing, except in an elimination series, and be delivered to the race office no later than the protest time limit or two hours after the incident, whichever is later. The protest committee shall extend the time if there is good reason to do so. No red flag is required.

SECTION B

HEARINGS AND DECISIONS

63 HEARINGS

63.1 Requirement for a Hearing

A kiteboard or competitor shall not be penalized without a protest hearing, except as provided in rules 30.2, 30.3, 67, 69 and A5. A decision on redress shall not be made without a hearing. The protest committee shall hear all *protests* and requests for redress that have been delivered to the race office unless it allows a *protest* or request to be withdrawn. [B2.6]

63.2 Time and Place of the Hearing; Time for Parties to Prepare

- (a) All *parties* to the hearing shall be notified of the time and place of the hearing, the *protest* or redress information shall be made available to them, and they shall be allowed reasonable time to prepare for the hearing.
- (b) In an elimination series, the protest committee may hear a *protest* or a request for redress on the beach or water immediately after the heat.

63.3 Right to Be Present

- (a) The *parties* to the hearing, or a representative of each, have the right to be present throughout the hearing of all the evidence. When a *protest* claims a breach of a rule of Part 2, 3 or 4, the representatives of kiteboards shall have been on kiteboard at the time of the incident, unless there is good reason for the protest committee to rule otherwise. Any witness, other than a member of the protest committee, shall be excluded except when giving evidence.

- (b) If a *party* to the hearing of a *protest* or request for redress does not come to the hearing, the protest committee may nevertheless decide the *protest* or request. If the *party* was unavoidably absent, the committee may reopen the hearing.

63.4 Interested Party

A member of a protest committee who is an *interested party* shall not take any further part in the hearing but may appear as a witness. Protest committee members must declare any possible self-interest as soon as they are aware of it. A *party* to the hearing who believes a member of the protest committee is an *interested party* shall object as soon as possible.

63.5 Validity of the Protest or Request for Redress

At the beginning of the hearing the protest committee shall take any evidence it considers necessary to decide whether all requirements for the *protest* or request for redress have been met. If they have been met, the *protest* or request is valid and the hearing shall be continued. If not, the committee shall declare the *protest* or request invalid and close the hearing. If the *protest* has been made under rule 60.3(a)(1), the committee shall also determine whether or not injury or serious damage resulted from the incident in question. If not, the hearing shall be closed.

63.6 Taking Evidence and Finding Facts

The protest committee shall take the evidence of the *parties* to the hearing and of their witnesses and other evidence it considers necessary. A member of the protest committee who saw the incident may give evidence. A *party* to the hearing may question any person who gives evidence. The committee shall then find the facts and base its decision on them.

63.7 Conflict between the Notice of Race and the Sailing Instructions

If there is a conflict between a rule in the notice of race and one in the sailing instructions that must be resolved before the protest committee can decide a *protest* or request for redress, the committee shall apply the rule that it believes will provide the fairest result for all boards affected.

63.8 Protests between Kiteboards in Different Races

A *protest* between kiteboards sailing in different races conducted by different organizing authorities shall be heard by a protest committee acceptable to those authorities.

64 DECISIONS

64.1 Penalties and Exoneration

- (a) When the protest committee decides that a kiteboard that is a *party* to a protest hearing has broken a *rule*, it shall disqualify her unless some other penalty applies. A penalty shall be imposed whether or not the applicable *rule* was mentioned in the *protest*.
- (b) If a kiteboard has taken an applicable penalty, rule 64.1(a) does not apply to her unless the penalty for a *rule* she broke is a disqualification that is not excludable from her series score.
- (c) When as a consequence of breaking a *rule* a kiteboard has compelled another kiteboard to break a *rule*, rule 64.1(a) does not apply to the other kiteboard and she shall be exonerated.
- (d) If a kiteboard has broken a *rule* when not *racing*, her penalty shall apply to the race sailed nearest in time to that of the incident.

64.2 Decisions on Redress

When the protest committee decides that a kiteboard is entitled to redress under rule 62, it shall make as fair an arrangement as possible for all kiteboards affected, whether or not they asked for redress. This may be to adjust the scoring (see rule A10 for some examples) or finishing times of kiteboards, to *abandon* the race, to let the results stand or to make some other arrangement. When in doubt about the facts or probable results of any arrangement for the race or series, especially before *abandoning* the race, the protest committee shall take evidence from appropriate sources.

64.3 Decisions on Measurement Protests

- (a) When the protest committee finds that deviations in excess of tolerances specified in the class rules were caused by damage or normal wear and do not improve the performance of the board, it shall not penalize her. However, the kiteboard shall not *race* again until the deviations have been corrected, except

when the protest committee decides there is or has been no reasonable opportunity to do so.

- (b) When the protest committee is in doubt about the meaning of a measurement rule, it shall refer its questions, together with the relevant facts, to an authority responsible for interpreting the rule. In making its decision, the committee shall be bound by the reply of the authority.
- (c) When a kiteboard disqualified under a measurement rule states in writing that she intends to appeal, she may compete in subsequent races without changes to the kiteboard, but shall be disqualified if she fails to appeal or the appeal is decided against her.
- (d) Measurement costs arising from a *protest* involving a measurement rule shall be paid by the unsuccessful *party* unless the protest committee decides otherwise.

65 INFORMING THE PARTIES AND OTHERS

65.1 After making its decision, the protest committee shall promptly inform the *parties* to the hearing of the facts found, the applicable *rules*, the decision, the reasons for it, and any penalties imposed or redress given.

65.2 Except in an elimination series, a *party* to the hearing is entitled to receive the above information in writing, provided she asks for it in writing from the protest committee no later than seven days after being informed of the decision. The committee shall then promptly provide the information, including, when relevant, a diagram of the incident prepared or endorsed by the committee.

65.3 When the protest committee penalizes a kiteboard under a measurement rule, it shall send the above information to the relevant measurement authorities.

66 REOPENING A HEARING

The protest committee may reopen a hearing when it decides that it may have made a significant error, or when significant new evidence becomes available within a reasonable time. It shall reopen a hearing when required by the national authority under rule F5. A *party* to the hearing may ask for a reopening no later than 24 hours after being informed of the decision. When a hearing is reopened, a majority of the

members of the protest committee shall, if possible, be members of the original protest committee.

67 Deleted. [B2.6]

68 **DAMAGES**

The question of damages arising from a breach of any *rule* shall be governed by the prescriptions, if any, of the national authority.

SECTION C

GROSS MISCONDUCT

69 **ALLEGATIONS OF GROSS MISCONDUCT**

69.1 **Action by a Protest Committee**

- (a) When a protest committee, from its own observation or a report received from any source, believes that a competitor may have committed a gross breach of a *rule*, good manners or sportsmanship, or may have brought the sport into disrepute, it may call a hearing. The protest committee shall promptly inform the competitor in writing of the alleged misconduct and of the time and place of the hearing. If the competitor provides good reason for being unable to attend the hearing, the protest committee shall reschedule it.
- (b) A protest committee of at least three members shall conduct the hearing, following the procedures in rules 63.2, 63.3(a), 63.4 and 63.6. If it decides that the competitor committed the alleged misconduct it shall either
 - (1) warn the competitor or
 - (2) impose a penalty by excluding the competitor and, when appropriate, disqualifying a board, from a race or the remaining races or all races of the series, or by taking other action within its jurisdiction. A disqualification under this rule shall not be excluded from the board's series score.
- (c) The protest committee shall promptly report a penalty, but not a warning, to the national authorities of the venue, of the com-

petitor and of the board owner. If the protest committee is an international jury appointed by the ISAF under rule 89.2(b), it shall send a copy of the report to the ISAF.

- (d) If the competitor does not provide good reason for being unable to attend the hearing and does not come to it, the protest committee may conduct it without the competitor present. If the committee does so and penalizes the competitor, it shall include in the report it makes under rule 69.1(c) the facts found, the decision and the reasons for it.
- (e) If the protest committee chooses not to conduct the hearing without the competitor present or if the hearing cannot be scheduled for a time and place when it would be reasonable for the competitor to attend, the protest committee shall collect all available information and, if the allegation seems justified, make a report to the relevant national authorities. If the protest committee is an international jury appointed by the ISAF under rule 89.2(b), it shall send a copy of the report to the ISAF.
- (f) When the protest committee has left the event and a report alleging misconduct is received, the race committee or organizing authority may appoint a new protest committee to proceed under this rule.

69.2 Action by a National Authority or Initial Action by the ISAF

- (a) When a national authority or the ISAF receives a report alleging a gross breach of a *rule*, good manners or sportsmanship, a report alleging conduct that has brought the sport into disrepute, or a report required by rule 69.1(c) or 69.1(e), it may conduct an investigation and, when appropriate, shall conduct a hearing. It may then take any disciplinary action within its jurisdiction it considers appropriate against the competitor or board, or other person involved, including suspending eligibility, permanently or for a specified period of time, to compete in any event held within its jurisdiction, and suspending ISAF eligibility under ISAF Regulation 19.
- (b) The national authority of a competitor shall also suspend the ISAF eligibility of the competitor as required in ISAF Regulation 19.
- (c) The national authority shall promptly report a suspension of eligibility under rule 69.2(a) to the ISAF, and to the national

authorities of the person or the owner of the board suspended if they are not members of the suspending national authority.

69.3 Subsequent Action by the ISAF

Upon receipt of a report required by rule 69.2(c) or ISAF Regulation 19, or following its own action under rule 69.2(a), the ISAF shall inform all national authorities, which may also suspend eligibility for events held within their jurisdiction. The ISAF Executive Committee shall suspend the competitor's ISAF eligibility as required in ISAF Regulation 19 if the competitor's national authority does not do so.

SECTION D

APPEALS

70 APPEALS AND REQUESTS TO A NATIONAL AUTHORITY

70.1 Provided that the right of appeal has not been denied under rule 70.5, a *party* to a hearing may appeal a protest committee's decision or its procedures, but not the facts found.

70.2 A protest committee may request confirmation or correction of its decision.

70.3 An appeal under rule 70.1 or a request by a protest committee under rule 70.2 shall be sent to the national authority with which the organizing authority is associated under rule 89.1. However, if boards will pass through the waters of more than one national authority while *racing*, the sailing instructions shall identify the national authority to which appeals or requests may be sent.

70.4 A club or other organization affiliated to a national authority may request an interpretation of the *rules*, provided that no *protest* or request for redress that may be appealed is involved. The interpretation shall not be used for changing a previous protest committee decision.

70.5 There shall be no appeal from the decisions of an international jury constituted in compliance with Appendix N. Furthermore, if the notice of race and the sailing instructions so state, the right of appeal may be denied provided that

- (a) it is essential to determine promptly the result of a race that will qualify a board to compete in a later stage of an event or a subsequent event (a national authority may prescribe that its approval is required for such a procedure);
- (b) a national authority so approves for a particular event open only to entrants under its own jurisdiction; or
- (c) a national authority after consultation with the ISAF so approves for a particular event, provided the protest committee is constituted as required by Appendix N, except that only two members of the protest committee need be International Judges.

70.6 Appeals and requests shall conform to Appendix F.

70.7 Appeals are not permitted in disciplines with elimination series. [B7.4]

71 NATIONAL AUTHORITY DECISIONS

71.1 No *interested party* or member of the protest committee shall take any part in the discussion or decision on an appeal or a request for confirmation or correction.

71.2 The national authority may uphold, change or reverse the protest committee's decision; declare the *protest* or request for redress invalid; or return the *protest* or request for the hearing to be reopened, or for a new hearing and decision by the same or a different protest committee.

71.3 When from the facts found by the protest committee the national authority decides that a kiteboard that was a *party* to a protest hearing broke a *rule*, it shall penalize her, whether or not that kiteboard or that *rule* was mentioned in the protest committee's decision.

71.4 The decision of the national authority shall be final. The national authority shall send its decision in writing to all *parties* to the hearing and the protest committee, who shall be bound by the decision.

PART 6

ENTRY AND QUALIFICATION

75 ENTERING A RACE

- 75.1** To enter a race, a kiteboard shall comply with the requirements of the organizing authority of the race. She shall be entered by
- (a) a member of a club or other organization affiliated to an ISAF member national authority,
 - (b) such a club or organization, or
 - (c) a member of an ISAF member national authority.
- 75.2** Competitors shall comply with ISAF Regulation 19, Eligibility Code.

76 EXCLUSION OF KITEBOARDS OR COMPETITORS

- 76.1** The organizing authority or the race committee may reject or cancel the entry of a kiteboard or exclude a competitor, subject to rule 76.2, provided it does so before the start of the first race and states the reason for doing so. However, the organizing authority or the race committee shall not reject or cancel the entry of a kiteboard or exclude a competitor because of advertising, provided the board or competitor complies with ISAF Regulation 20, Advertising Code.
- 76.2** At world and continental championships no entry within stated quotas shall be rejected or cancelled without first obtaining the approval of the relevant international class association (or the Offshore Racing Council) or the ISAF.

77 IDENTIFICATION ON SAILS

A kiteboard shall comply with the simple set of the requirements of Appendix G.

78 COMPLIANCE WITH CLASS RULES; CERTIFICATES

- 78.1** A kiteboard's owner and any other person in charge shall ensure that the board is maintained to comply with her class rules and that her measurement or rating certificate, if any, remains valid. When so prescribed by the ISAF, a numbered and dated device on a kiteboard and her centreboard, fin and rig shall serve as her measurement certificate [B2.2].

78.2 When a *rule* requires a certificate to be produced before a kiteboard *aces*, and it is not produced, the kiteboard may *ace* provided that the race committee receives a statement signed by the person in charge that a valid certificate exists and that it will be given to the race committee before the end of the event. If the certificate is not received in time, the kiteboard shall be disqualified from all races of the event.

78.3 When an equipment inspector or a measurer for an event decides that a kiteboard or personal equipment does not comply with the class rules, he shall report the matter in writing to the race committee.

79 CLASSIFICATION

If the notice of race or class rules state that some or all competitors must satisfy classification requirements, the classification shall be carried out as described in ISAF Regulation 22, Sailor Classification Code.

80 ADVERTISING

A kiteboard and her crew shall comply with ISAF Regulation 20, Advertising Code.

81 RESCHEDULED RACES

When a race has been rescheduled, all kiteboards entered in the original race shall be notified. New entries that meet the entry requirements of the original race may be accepted at the discretion of the race committee.

PART 7

RACE ORGANIZATION

85 GOVERNING RULES

The organizing authority, race committee and protest committee shall be governed by the *rules* in the conduct and judging of races.

86 CHANGES TO THE RACING RULES

86.1 A racing rule shall not be changed unless permitted in the rule itself or as follows:

- (a) Prescriptions of a national authority may change a racing rule, but not the Definitions; a rule in the Introduction; Sportsmanship and the Rules; Part 1, 2 or 7; rule 42, 43, 69, 70, 71, 75, 76.2, 79 or 80; a rule of an appendix that changes one of these rules; Appendix H or N; or ISAF Regulation 19, 20, 21 or 22.
- (b) Sailing instructions may change a racing rule but not rule 76.1, Appendix F, or a rule listed in rule 86.1(a). If the sailing instructions change a rule or that definition, they shall refer specifically to the rule or definition and state the change.
- (c) Class rules may change only racing rules 42, 49, 50, 51, 52, 53 and 54. Such changes shall refer specifically to the rule and state the change.

Note: The second sentence of this rule takes effect on 1 January 2011.

86.2 In exception to rule 86.1, the ISAF may in limited circumstances (see ISAF Regulation 31.1.3) authorize changes to the racing rules for a specific international event. The authorization shall be stated in a letter of approval to the event organizing authority and in the notice of race and sailing instructions, and the letter shall be posted on the event's official notice board.

86.3 If a national authority so prescribes, the restrictions in rule 86.1 do not apply if rules are changed to develop or test proposed rules. The national authority may prescribe that its approval is required for such changes.

87 CHANGES TO CLASS RULES

The sailing instructions may change a class rule only when the class rules permit the change, or when written permission of the class association for the change is displayed on the official notice board.

88 NATIONAL PRESCRIPTIONS

88.1 The prescriptions that apply to an event are the prescriptions of the national authority with which the organizing authority is associated under rule 89.1. However, if kiteboards will pass through the waters of more than one national authority while *racing*, the sailing instructions shall identify any other prescriptions that will apply and when they will apply.

88.2 The sailing instructions may change a prescription. However, a national authority may restrict changes to its prescriptions with a prescription to this rule, provided the ISAF approves its application to do so. The restricted prescriptions shall not be changed by the sailing instructions.

89 ORGANIZING AUTHORITY; NOTICE OF RACE; APPOINTMENT OF RACE OFFICIALS

89.1 Organizing Authority

Races shall be organized by an organizing authority, which shall be

- (a) the ISAF;
- (b) a member national authority of the ISAF;
- (c) a club or other organization affiliated to a national authority;
- (d) a class association, either with the approval of a national authority or in conjunction with an affiliated club;
- (e) an unaffiliated body in conjunction with an affiliated club where the body is owned and controlled by the club. The national authority of the club may prescribe that its approval is required for such an event; or
- (f) if approved by the ISAF and the national authority of the club, an unaffiliated body in conjunction with an affiliated club where the body is not owned and controlled by the club.

89.2 Notice of Race; Appointment of Race Officials

- (a) The organizing authority shall publish a notice of race that conforms to rule J1. The notice of race may be changed provided adequate notice is given.
- (b) The organizing authority shall appoint a race committee and, when appropriate, appoint a protest committee and umpires. However, the race committee, an international jury and umpires may be appointed by the ISAF as provided in the ISAF regulations.

90 RACE COMMITTEE; SAILING INSTRUCTIONS; SCORING

90.1 Race Committee

The race committee shall conduct races as directed by the organizing authority and as required by the *rules*.

90.2 Sailing Instructions

- (a) The race committee shall publish written sailing instructions that conform to rule J2.
- (b) When appropriate, for an event where entries from other countries are expected, the sailing instructions shall include, in English, the applicable national prescriptions.
- (c) Changes to the sailing instructions shall be in writing and posted on the official notice board before the time stated in the sailing instructions or, on the water, communicated to each kiteboard before her warning signal. **[B2.3(a)]**
- (d) Oral instructions may be given only if the procedure is stated in the sailing instructions. **[B2.3(b)]**

90.3 Scoring

- (a) The race committee shall score a race or series as provided in Appendix A using the Low Point System, unless the sailing instructions specify the Bonus Point System or some other system. A race shall be scored if it is not *abandoned* and if one board sails the course in compliance with rule 28.1 and *finishes* within the time limit, if any, even if she retires after *finishing* or is disqualified.

- (b) When a scoring system provides for excluding one or more race scores from a kiteboard's series score, the score for disqualification under rule 2; rule 30.3's last sentence; or rule 69.1(b)(2) shall not be excluded. The next-worse score shall be excluded instead.

91 PROTEST COMMITTEE

A protest committee shall be

- (a) a committee appointed by the organizing authority or race committee, or
- (b) an international jury appointed by the organizing authority or as prescribed in the ISAF regulations and meeting the requirements of Appendix N. A national authority may prescribe that its approval is required for the appointment of international juries for races within its jurisdiction, except ISAF events or when international juries are appointed by the ISAF under rule 89.2(b).

APPENDIX A

SCORING

See rule 90.3.

A1 NUMBER OF RACES

A1.1 Number of Races in Course Format

The number of races scheduled and the number required to be completed to constitute a series shall be stated in the sailing instructions.

A1.2 Overall Scores [B8.1]

If an event includes more than one discipline or format the sailing instructions shall state how the overall score is to be calculated.

A2 SERIES SCORES [B8.2]

Each kiteboard's series score shall be the total of her race, elimination series or speed round scores with the number of her worst scores excluded as follows:

<i>Course races</i>	<i>Speed rounds</i>	<i>Slalom and expression elimination series</i>	<i>Number excluded</i>
1–4	1–3	1–2	0
5–11	4–6	3–4	1
12 or more	7–10	5–7	2
	11–15	8 or more	3
	16 or more		4

If a kiteboard has two or more equal worst scores, the score(s) for the race(s) sailed earliest in the series shall be excluded. The kiteboard with the lowest series score wins and others shall be ranked accordingly. Rules A4.4, A4.5 and A4.6 contain exceptions to this rule.

A3 STARTING TIMES AND FINISHING PLACES

The time of a kiteboard's starting signal shall be her starting time, and the order in which kiteboards *finish* a race shall determine their

finishing places. However, when a handicap or rating system is used a kiteboard's corrected time shall determine her finishing place.

A4 LOW POINT AND ALTERNATIVE SYSTEMS

Most series are scored using either the Low Point System or the Bonus Point System. The Low Point System uses a board's finishing place as her race score. The Bonus Point System benefits the first six finishers because of the greater difficulty in advancing from fourth place to third, for example, than from fourteenth place to thirteenth. The Low Point System will apply unless the sailing instructions specify another system; see rule 90.3(a). If the Bonus Point System is chosen it can be made to apply by stating in the sailing instructions that 'The Bonus Point System of Appendix A will apply.'

- A4.1** Each board *starting and finishing* and not thereafter retiring, being penalized or given redress shall be scored points as follows:

<i>Finishing place</i>	<i>Low Point System</i>	<i>Bonus Point System</i>
First	1	0
Second	2	3
Third	3	5.7
Fourth	4	8
Fifth	5	10
Sixth	6	11.7
Seventh	7	13
Each place thereafter	Add 1 point	Add 1 point

- A4.2** A board that did not *start*, did not *finish*, retired after *finishing* or was disqualified shall be scored points for the finishing place one more than the number of boards entered in the series or in an elimination series the number of boards in that heat. A kiteboard that is penalized under rule 30.2 or that takes a penalty under rule 44.2(a) shall be scored points as provided in rule 44.2(b). **[B8.3]**

A4.3 Uncompleted Heat [B8.4]

When a heat cannot be completed, the points for the unscored places shall be added together and divided by the number of places in that heat. The resulting number of points, to the nearest tenth of a point

(0.05 to be rounded upward), shall be given to each board entered in the heat.

A4.4 Scoring a Final Series in Racing with Elimination [B8.5]

- (a) If three final races are completed, a kiteboard's series score in the final shall be the total of her race scores excluding her worst score. Otherwise her series score shall be the total of her race scores.
- (b) A kiteboard that did not *start*, did not *finish*, retired after *finishing* or was disqualified from a final race shall be scored points equal to the total number of kiteboards entered in the final.

A4.5 Expression Competition Scoring [B8.6]

- (a) Expression competition shall be scored by a panel of three judges. However, the panel may have a greater odd number of members, and there may be two such panels. Each judge shall give points for each manoeuvre based on the scale stated in the sailing instructions.
- (b) The criteria of scoring shall be decided by the race committee and announced on the official notice board no later than 30 minutes before the starting signal for the first heat.
- (c) A kiteboard's heat standing shall be determined by adding together the points given by each judge. The kiteboard with the highest score wins and others shall be ranked accordingly.
- (d) Both semi-final heats shall have been sailed for an elimination series to be valid.
- (e) Except for members of the race committee responsible for scoring the event, only competitors in the heat shall be allowed to see judges' score sheets for the heat. Each score sheet shall bear the full name of the judge.
- (f) Scoring decisions of the judges shall not be grounds for a request for redress by a kiteboard.

A4.6 Speed Competition [B8.7]

The speeds of a kiteboard's fastest two runs in a round shall be averaged to determine her standing in that round. The kiteboard with the highest average wins and others shall be ranked accordingly.

A5 SCORES DETERMINED BY THE RACE COMMITTEE

A kiteboard that did not *start*, comply with rule 30.3 or *finish*, or that retires after *finishing*, shall be scored accordingly by the race committee without a hearing. Only the protest committee may take other scoring actions that worsen a kiteboard's score.

A6 CHANGES IN PLACES AND SCORES OF OTHER BOARDS

A6.1 If a kiteboard is disqualified from a race or retires after *finishing*, each kiteboard with a worse finishing place shall be moved up one place.

A6.2 If the protest committee decides to give redress by adjusting a kiteboard's score, the scores of other boards shall not be changed unless the protest committee decides otherwise.

A7 RACE TIES

If kiteboards are tied at the finishing line or if a handicap or rating system is used and kiteboards have equal corrected times, the points for the place for which the kiteboards have tied and for the place(s) immediately below shall be added together and divided equally. Kiteboards tied for a race prize shall share it or be given equal prizes.

A8 SERIES TIES [B8.8]

A8.1 RACING AND SPEED COMPETITION

(a) If there is a series-score tie between two or more kiteboards, it shall be broken in favour of the kiteboard(s) with the best single excluded race score(s).

(b) If a tie remains between two or more kiteboards, each kiteboard's race scores shall be listed in order of best to worst, and at the first point(s) where there is a difference the tie shall be broken in favour of the kiteboard(s) with the best score(s). These scores shall be used even if some of them are excluded scores.

(c) If a tie still remains between two or more kiteboards, they shall be ranked in order of their scores in the last race. Any remaining ties shall be broken by using the tied kiteboards' scores in the next-to-last race and so on until all ties are broken. These scores shall be used even if some of them are excluded scores.

A8.2 EXPRESSION COMPETITION

- (a) In a heat, if there is a tie in the total points given by one or more judges, it shall be broken in favour of the kiteboard with the higher single score in the priority category. If the categories are weighted equally, in wave performance competition the tie shall be broken in favour of the kiteboard with the higher single score in wave riding, and in freestyle competition in favour of the kiteboard with the higher score for overall impression. If a tie remains, in wave performance competition it shall be broken in favour of the kiteboard with the higher single score in the category without priority, and in freestyle competition it shall stand as the final result.
- (b) If there is a tie in the series score, it shall be broken in favour of the kiteboard that scored better more times than the other kiteboard. All scores shall be used even if some of them are excluded scores.
- (c) If a tie still remains, the heat shall be resailed. If this is not possible, the tie shall stand as the final result.

A9 RACE SCORES IN A SERIES LONGER THAN A REGATTA

For a series that is held over a period of time longer than a regatta, a kiteboard that came to the starting area but did not *start*, did not *finish*, retired after *finishing* or was disqualified shall be scored points for the finishing place one more than the number of kiteboards that came to the starting area. A kiteboard that did not come to the starting area shall be scored points for the finishing place one more than the number of kiteboards entered in the series.

A10 GUIDANCE ON REDRESS

If the protest committee decides to give redress by adjusting a kiteboard's score for a race, it is advised to consider scoring her

- (a) points equal to the average, to the nearest tenth of a point (0.05 to be rounded upward), of her points in all the races in the series except the race in question;
- (b) points equal to the average, to the nearest tenth of a point (0.05 to be rounded upward), of her points in all the races before the race in question; or

- (c) points based on the position of the kiteboard in the race at the time of the incident that justified redress.

A11 SCORING ABBREVIATIONS

These scoring abbreviations shall be used for recording the circumstances described:

DNC	Did not <i>start</i> ; did not come to the starting area
DNS	Did not <i>start</i> (other than DNC and OCS)
OCS	Did not <i>start</i> ; on the course side of the starting line at her starting signal and failed to <i>start</i> , or broke rule 30.1
ZFP	20% penalty under rules 30.3 and 44
BFD	Disqualification under rule 30.3
DNF	Did not <i>finish</i>
RAF	Retired after <i>finishing</i>
DSQ	Disqualification
DNE	Disqualification (other than DGM); not excludable under rule 90.3(b)
DGM	Disqualification for gross misconduct not excludable under rule 90.3(b)
RDG	Redress given

APPENDIX F

PROCEDURES FOR APPEALS AND REQUESTS

See rule 70. A national authority may change this appendix by prescription but it shall not be changed by sailing instructions.

F1 APPEALS AND REQUESTS

Appeals, requests by protest committees for confirmation or correction of their decisions, and requests for interpretations of the *rules* shall be made in compliance with this appendix.

F2 SUBMISSION OF DOCUMENTS

F2.1 No later than 15 days after receiving the protest committee's written decision or its decision not to reopen a hearing, the appellant shall send an appeal and a copy of the protest committee's decision to the national authority. The appeal shall state why the appellant believes the protest committee's decision or its procedures were incorrect.

F2.2 The appellant shall also send, with the appeal or as soon as possible thereafter, all of the following documents that are available to her:

- (a) the written *protest(s)* or request(s) for redress;
- (b) a diagram, prepared or endorsed by the protest committee, showing the positions and tracks of all boards involved, the course to the next *mark* and the required side, the force and direction of the wind, and, if relevant, the depth of water and direction and speed of any current;
- (c) the notice of race, the sailing instructions, any other conditions governing the event, and any changes to them;
- (d) any additional relevant documents; and
- (e) the names, postal and e-mail addresses, and telephone numbers of all *parties* to the hearing and the protest committee chairman.

F2.3 A request from a protest committee for confirmation or correction of its decision shall be sent no later than 15 days after the decision and

shall include the decision and the documents listed in rule F2.2. A request for an interpretation of the *rules* shall include assumed facts.

F3 RESPONSIBILITIES OF NATIONAL AUTHORITY AND PROTEST COMMITTEE

Upon receipt of an appeal or a request for confirmation or correction, the national authority shall send to the *parties* and protest committee copies of the appeal or request and the protest committee's decision. It shall ask the protest committee for any relevant documents listed in rule F2.2 not sent by the appellant or the protest committee, and the protest committee shall promptly send them to the national authority. When the national authority has received them it shall send copies to the *parties*.

F4 COMMENTS

The *parties* and protest committee may make comments on the appeal or request or on any of the documents listed in rule F2.2 by sending them in writing to the national authority. Comments on any document shall be made no later than 15 days after receiving it from the national authority. The national authority shall send copies of the comments to the *parties* and protest committee as appropriate.

F5 INADEQUATE FACTS; REOPENING

The national authority shall accept the protest committee's finding of facts except when it decides they are inadequate. In that case it shall require the committee to provide additional facts or other information, or to reopen the hearing and report any new finding of facts, and the committee shall promptly do so.

F6 WITHDRAWING AN APPEAL

An appellant may withdraw an appeal before it is decided by accepting the protest committee's decision.

APPENDIX G

IDENTIFICATION ON SAILS

See rule 77.

G1 ISAF INTERNATIONAL CLASS KITEBOARDS

G1.1 Identification [BB2.4]

Every kiteboard of an ISAF International Class or Recognized Class shall carry in 2009 events identifications as follow:

- (a) Each competitor shall be provided an event lycra with a personal competition number
- (b) The numbers shall be of maximum three digits
- (c) The numbers shall be displayed on front and back side of the lycra with a minimum height of 15 cm
- (d) The numbers shall be displayed on both sleeves with a minimum height of 5 cm
- (e) The colour of the numbers shall be contrasting to the lycra and clearly readable

NATIONAL SAIL LETTERS

<i>National authority</i>	<i>Letters</i>		
Bermuda	BER	Bermuda	BER
Algeria	ALG	Brazil	BRA
American Samoa	ASA	British Virgin Islands	IVB
Andorra	AND	Bulgaria	BUL
Angola	ANG	Canada	CAN
Antigua	ANT	Cayman Islands	CAY
Argentina	ARG	Chile	CHI
Armenia	ARM	China, PR	CHN
Australia	AUS	Chinese Taipei	TPE
Austria	AUT	Colombia	COL
Azerbaijan	AZE	Cook Islands	COK
Bahamas	BAH	Croatia	CRO
Bahrain	BRN	Cuba	CUB
Barbados	BAR	Cyprus	CYP
Belarus	BLR	Czech Republic	CZE
Belgium	BEL	Denmark	DEN

Appendix G IDENTIFICATION ON SAILS

Dominican Republic	DOM	Malaysia	MAS
Ecuador	ECU	Malta	MLT
Egypt	EGY	Mauritius	MRI
El Salvador	ESA	Mexico	MEX
Estonia	EST	<i>National authority</i>	<i>Letters</i>
<i>National authority</i>	<i>Letters</i>	Micronesia (FSO)	FSM
Fiji	FIJ	Moldova	MDA
Finland	FIN	Monaco	MON
France	FRA	Montenegro	MNE
Georgia	GEO	Morocco	MAR
Germany	GER	Myanmar	MYA
Great Britain	GBR	Namibia	NAM
Greece	GRE	Netherlands	NED
Grenada	GRN	Netherlands Antilles	AHO
Guam	GUM	New Zealand	NZL
Guatemala	GUA	Norway	NOR
Hong Kong	HKG	Oman	OMA
Hungary	HUN	Pakistan	PAK
Iceland	ISL	Palestine	PLE
India	IND	Papua New Guinea	PNG
Indonesia	INA	Paraguay	PAR
Ireland	IRL	Peru	PER
Israel	ISR	Philippines	PHI
Italy	ITA	Poland	POL
Jamaica	JAM	Portugal	POR
Japan	JPN	Puerto Rico	PUR
Kazakhstan	KAZ	Qatar	QAT
Kenya	KEN	Romania	ROU
Korea	KOR	Russia	RUS
Kuwait	KUW	Samoa	SAM
Kyrgyzstan	KGZ	San Marino	SMR
Latvia	LAT	<i>National authority</i>	<i>Letters</i>
Lebanon	LIB	Senegal	SEN
Libya	LBA	Serbia	SRB
Liechtenstein	LIE	Seychelles	SEY
Lithuania	LTU	Singapore	SIN
Luxembourg	LUX	Slovak Republic	SVK
Macedonia (FYRO)	MKD		

Appendix G IDENTIFICATION ON SAILS

Slovenia	SLO	Tunisia	TUN
Solomon Islands	SOL	Turkey	TUR
South Africa	RSA	Ukraine	UKR
Spain	ESP	United Arab Emirates	UAE
Sri Lanka	SRI	United States of America	USA
St Lucia	LCA	Uruguay	URU
Sweden	SWE	US Virgin Islands	ISV
Switzerland	SUI	Vanuatu	VAN
Tahiti	TAH	Venezuela	VEN
Thailand	THA	Zimbabwe	ZIM
Trinidad & Tobago	TRI		

Note: An up-to-date list is available on the ISAF website.

APPENDIX H

WEIGHING CLOTHING AND EQUIPMENT

See rule 43. This appendix shall not be changed by sailing instructions or prescriptions of national authorities.

- H1** Items of clothing and equipment to be weighed shall be arranged on a rack. After being saturated in water the items shall be allowed to drain freely for one minute before being weighed. The rack must allow the items to hang as they would hang from clothes hangers, so as to allow the water to drain freely. Pockets that have drain-holes that cannot be closed shall be empty, but pockets or items that can hold water shall be full.
- H2** When the weight recorded exceeds the amount permitted, the competitor may rearrange the items on the rack and the equipment inspector or measurer shall again soak and weigh them. This procedure may be repeated a second time if the weight still exceeds the amount permitted.
- H3** A competitor wearing a dry suit may choose an alternative means of weighing the items.
- (a) The dry suit and items of clothing and equipment that are worn outside the dry suit shall be weighed as described above.
 - (b) Clothing worn underneath the dry suit shall be weighed as worn while *racing*, without draining.
 - (c) The two weights shall be added together.

APPENDIX J

NOTICE OF RACE AND SAILING INSTRUCTIONS

See rules 89.2(a) and 90.2. The term 'race' includes a regatta or other series of races.

J1 NOTICE OF RACE CONTENTS

J1.1 The notice of race shall include the following information:

- (1) the title, place and dates of the race and name of the organizing authority;
- (2) that the race will be governed by the *rules* as defined in *The Racing Rules of Sailing* as changed by *the Windsurfing Competition Rules* or, equivalently, under *The Experimental Kiteboarding Competition Rules*;
- (3) a list of any other documents that will govern the event (for example, *The Equipment Rules of Sailing*, to the extent that they apply), stating where or how each document or a copy of it may be seen;
- (4) the classes to race, any handicap or rating system that will be used and the classes to which it will apply, conditions of entry and any restrictions on entries;
- (5) the times of registration and warning signals for the practice race, if one is scheduled, and the first race, and succeeding races if known.

J1.2 The notice of race shall include any of the following that will apply and that would help competitors decide whether to attend the event or that conveys other information they will need before the sailing instructions become available:

- (1) identification of any racing rules that will be changed, a summary of the changes, and a statement that the changes will appear in full in the sailing instructions (see rule 86);
- (2) that advertising will be restricted to Category A or that kiteboards will be required to display advertising chosen and sup-

- plied by the organizing authority (see ISAF Regulation 20) and other information related to Regulation 20;
- (3) any classification requirements that some or all competitors must satisfy (see rule 79 and ISAF Regulation 22, Sailor Classification Code);
 - (4) for an event where entries from other countries are expected, any national prescriptions that may require advance preparation;
 - (5) the procedure for advance registration or entry, including fees and any closing dates;
 - (6) an entry form, to be signed by the kiteboard's owner or owner's representative, containing words such as 'I agree to be bound by *The Racing Rules of Sailing* as changed by *the Windsurfing Competition Rules* or, equivalently, under *The Experimental Kiteboarding Competition Rules* and by all other rules that govern this event';
 - (7) equipment inspection, measurement procedures or requirements for measurement certificates or for handicap or rating certificates;
 - (8) the time and place at which the sailing instructions will be available;
 - (9) changes to class rules, as permitted under rule 87, referring specifically to each rule and stating the change;
 - (10) the courses to be sailed;
 - (11) the penalty for breaking a rule of Part 2, other than the One-Turn Penalty;
 - (12) denial of the right of appeal, subject to rule 70.5;
 - (13) the scoring system, if different from the Low Point System in Appendix A, the number of races scheduled and the minimum number that must be completed to constitute a series;
 - (14) prizes.

J2 SAILING INSTRUCTION CONTENTS

J2.1 The sailing instructions shall include the following information:

- (1) that the race will be governed by the rules as defined in *The Racing Rules of Sailing* as changed by *the Windsurfing Compe-*

tition Rules or, equivalently, under *The Experimental Kiteboarding Competition Rules*.

- (2) a list of any other documents that will govern the event (for example, *The Equipment Rules of Sailing*, to the extent that they apply);
- (3) the schedule of races, the classes to race and times of warning signals for each class;
- (4) the course(s) to be sailed, or a list of *marks* from which the course will be selected and, if relevant, how courses will be signalled;
- (5) descriptions of *marks*, including starting and finishing *marks*, stating the order and side on which each is to be left and identifying all rounding *marks* (see rule 28.1);
- (6) descriptions of the starting and finishing lines, class flags and any special signals to be used;
- (7) the time limit, if any, for *finishing*;
- (8) the handicap or rating system to be used, if any, and the classes to which it will apply;
- (9) the scoring system, if different from the Low Point System in Appendix A, included by reference to Appendix A, to class rules or other *rules* governing the event, or stated in full. State the number of races scheduled and the minimum number that must be completed to constitute a series.

J2.2 The sailing instructions shall include those of the following that will apply:

- (1) that advertising will be restricted to Category A (see ISAF Regulation 20) and other information related to Regulation 20;
- (2) replacement of the rules of Part 2 with the right-of-way rules of the *International Regulations for Preventing Collisions at Sea* or other government right-of-way rules, the time(s) or place(s) they will apply, and any night signals to be used by the race committee;
- (3) changes to the racing rules permitted by rule 86, referring specifically to each rule and stating the change (if rule 86.2 applies, state the authorization);
- (4) changes to the national prescriptions (see rule 88);

- (5) when appropriate, at an event where entries from other countries are expected, a copy in English of the national prescriptions that will apply;
- (6) changes to class rules, as permitted under rule 87, referring specifically to each rule and stating the change;
- (7) restrictions controlling changes to kiteboards when supplied by the organizing authority;
- (8) the registration procedure;
- (9) measurement or inspection procedure;
- (10) location(s) of official notice kiteboard(s);
- (11) procedure for changing the sailing instructions;
- (12) safety requirements, such as requirements and signals for personal flotation devices, check-in at the starting area, and check-out and check-in ashore;
- (13) declaration requirements;
- (14) signals to be made ashore and location of signal station(s);
- (15) the racing area (a chart is recommended);
- (16) approximate course length and approximate length of windward legs;
- (17) description of any area designated by the race committee to be an *obstruction* (see the definition *Obstruction*);
- (18) the time limit, if any, for the first kiteboard to *finish* and the time limit, if any, for kiteboards other than the first kiteboard to *finish*;
- (19) time allowances;
- (20) the location of the starting area and any restrictions on entering it;
- (21) any special procedures or signals for individual or general recall;
- (22) boats identifying *mark* locations;
- (23) any special procedures or signals for changing a leg of the course (see rule 33);
- (24) any special procedures for shortening the course or for *finishing* a shortened course;

- (25) restrictions on use of support boats, plastic pools, radios, etc.; on trash disposal; on hauling out; and on outside assistance provided to a kiteboard that is not *racing*;
- (26) the penalty for breaking a rule of Part 2, other than the One-Turn Penalty;
- (27) not needed; [**Zone not used in Appendix B**]
- (28) deleted; [**B2.6**]
- (29) protest procedure and times and place of hearings;
- (30) if rule N1.4(b) will apply, the time limit for requesting a hearing under that rule;
- (31) when required by rule 70.3, the national authority to which appeals and requests may be sent and, when applicable, subject to rule 70.5 denial of the right of appeal;
- (32) the national authority's approval of the appointment of an international jury, when required under rule 91(b);
- (33) deleted; [**B2.6**]
- (34) the minimum number of kiteboards appearing in the starting area required for a race to be started;
- (35) when and where races *postponed* or *abandoned* for the day will be resailed;
- (36) tides and currents;
- (37) prizes;
- (38) other commitments of the race committee and obligations of kiteboards.

APPENDIX K

NOTICE OF RACE GUIDE

This guide provides a notice of race designed primarily for major championship regattas for one or more classes. It therefore will be particularly useful for world, continental and national championships and other events of similar importance. It can be downloaded from the ISAF website (www.sailing.org) as a basic text for producing a notice of race for any particular event.

The guide can also be useful for other events. However, for such events some of the paragraphs will be unnecessary or undesirable. Organizing authorities should therefore be careful in making their choices.

APPENDIX L

SAILING INSTRUCTIONS GUIDE

This guide provides a set of tested sailing instructions designed primarily for major championship regattas for one or more classes. It therefore will be particularly useful for world, continental and national championships and other events of similar importance. The guide can also be useful for other events; however, for such events some of these instructions will be unnecessary or undesirable. Race officers should therefore be careful in making their choices.

An expanded version of the guide, Appendix LE, is available on the ISAF website (www.sailing.org). It contains provisions applicable to the largest and most complicated multi-class events, as well as variations on several of the sailing instructions recommended in this appendix. It will be revised from time to time, to reflect advances in race management techniques as they develop, and can be downloaded as a basic text for producing the sailing instructions for any particular event. Appendix L can also be downloaded from the ISAF website.

The principles on which all sailing instructions should be based are as follows:

- 1 They should include only two types of statement: the intentions of the race committee and protest committee and the obligations of competitors.*
- 2 They should be concerned only with racing. Information about social events, assignment of moorings, etc., should be provided separately.*
- 3 They should not change the racing rules except when clearly desirable. (When they do so, they must follow rule 86 by referring specifically to the rule being changed and stating the change.)*
- 4 They should not repeat or restate any of the racing rules.*
- 5 They should not repeat themselves.*
- 6 They should be in chronological order; that is, the order in which the competitor will use them.*
- 7 They should, when possible, use words or phrases from the racing rules.*

Remark: Use the rest of Appendix L as it is in the RRS2009-2012 except Addendum A and Addendum B to Appendix L

ADDENDUM A

ILLUSTRATING THE COURSE

Shown here are diagrams of course shapes. The kiteboard's track is represented by a discontinuous line so that each diagram can describe courses with different numbers of laps. If more than one course may be used for a class, state how each particular course will be signalled.

Courses for Kiteboard Course Racing

A Windward-Leeward Course

Start – 1 – 2 – 1 – 2 – Finish

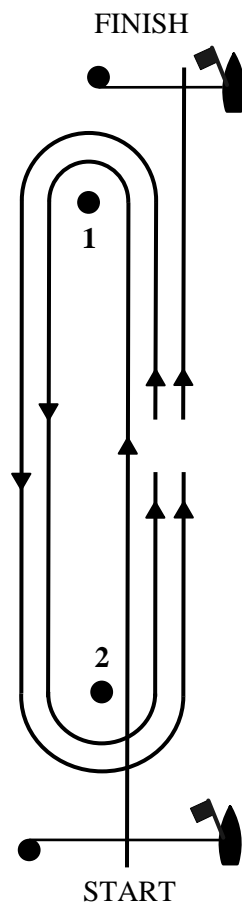

Options for this course include

- (1) increasing or decreasing the number of laps,*
- (2) deleting the last windward leg,*
- (3) using a gate instead of a leeward mark,*
- (4) using an offset mark at the windward mark, and*

- (5) *using the leeward and windward marks as starting and finishing marks.*

A Windward-Leeward-Triangle Course

Start – 1 – 2 – 3 – 1 – 3 – Finish

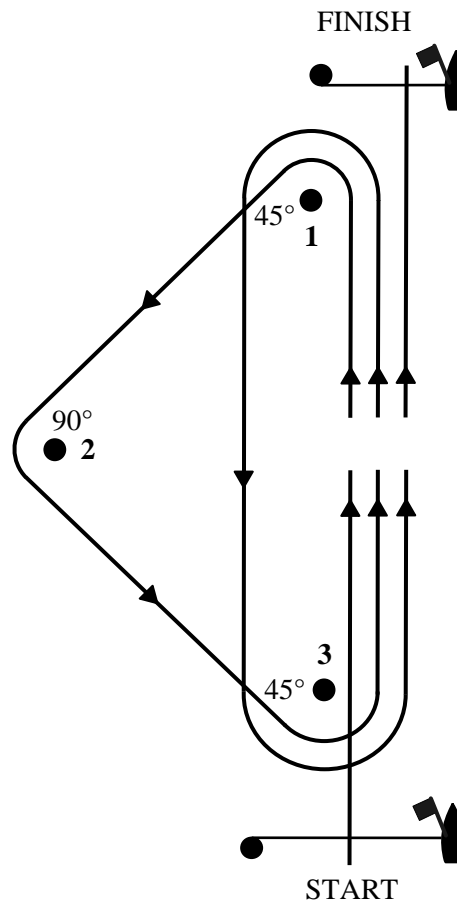

Options for this course include

- (1) *increasing or decreasing the number of laps,*
- (2) *deleting the last windward leg,*
- (3) *varying the interior angles of the triangle (45°–90°–45° and 60°–60°–60° are common),*
- (4) *using a gate instead of a leeward mark for downwind legs,*
- (5) *using an offset mark at the beginning of downwind legs, and*
- (6) *using the leeward and windward marks as starting and finishing marks.*

Be sure to specify the interior angle at each mark.

Trapezoid Courses

Start – 1 – 2 – 3 – 2 – 3 – Finish

Start – 1 – 4 – 1 – 2 – 3 – Finish

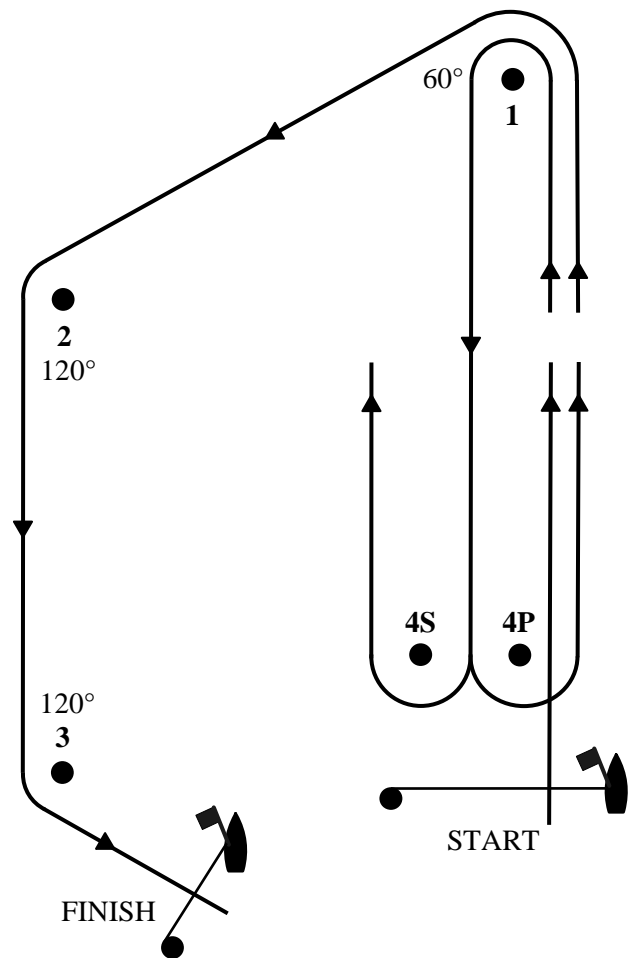
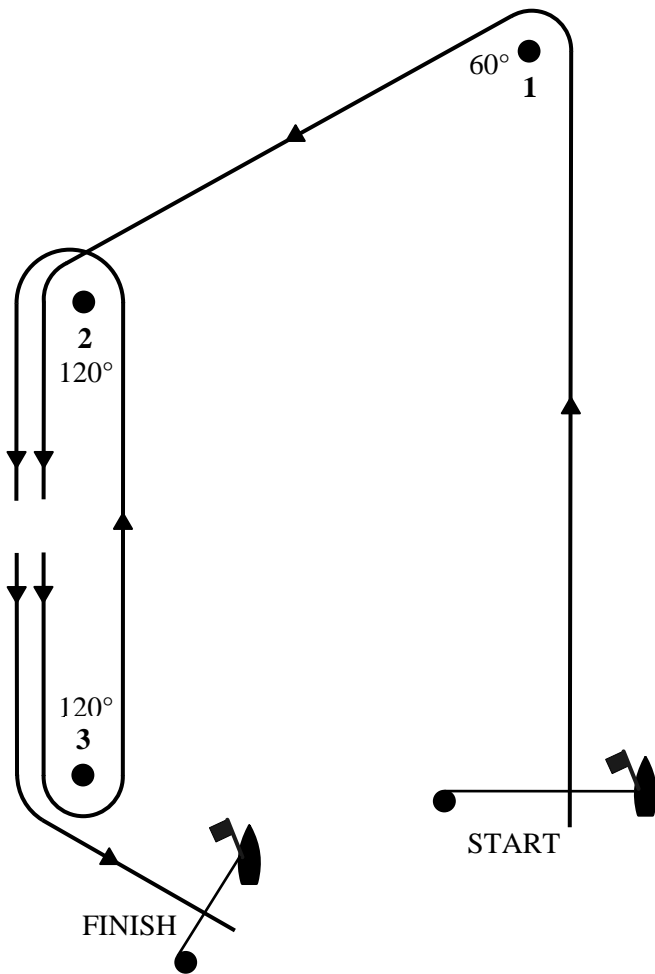

Options for these courses include

- (1) adding additional legs,*
- (2) replacing the gate shown by a single mark, or using a gate also in the outer loop,*
- (3) varying the interior angles of the reaching legs,*
- (4) using an offset mark at the beginning of downwind legs, and*
- (5) finishing boats upwind rather than on a reach.*

Be sure to specify the interior angle of each reaching leg.

Standard Square Course

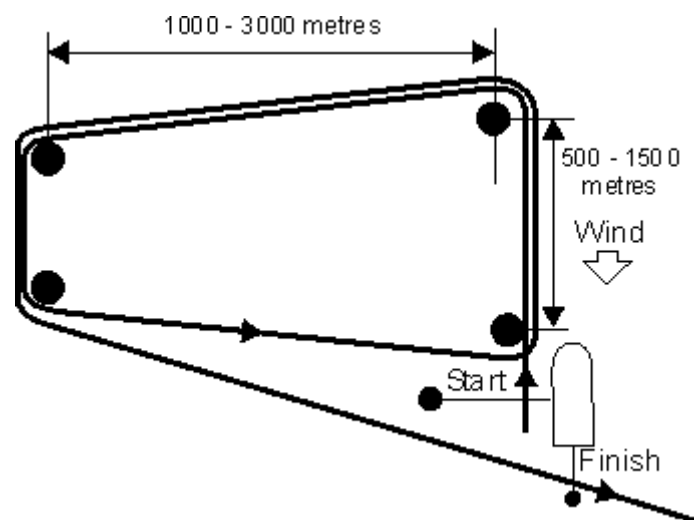

Alternative Emergency Course

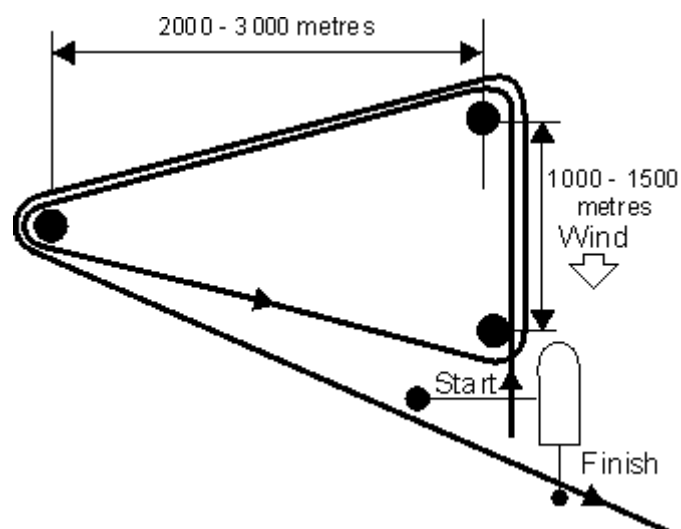

Note: The Alternative Emergency Course, or a course with three gybing marks, shall be used in very rough conditions, when the Standard Square Course cannot be set in a timely fashion.

Courses for RACING WITH ELIMINATION SERIES

Figure of Eight Course

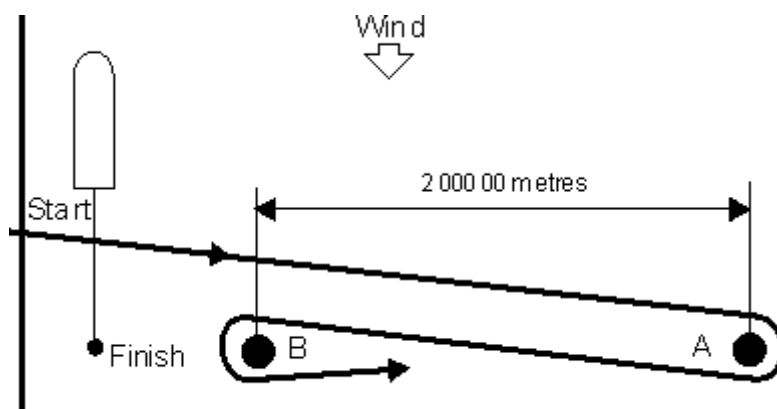

Note: The start can be from the beach or on the water near marks A or B. If the wind is not cross shore, starts should normally be on water. The finishing line can be set to windward or leeward of mark B, on the water or on the beach. The distance between A and B is to be between 200 and 600 meters.

Downwind Slalom Course

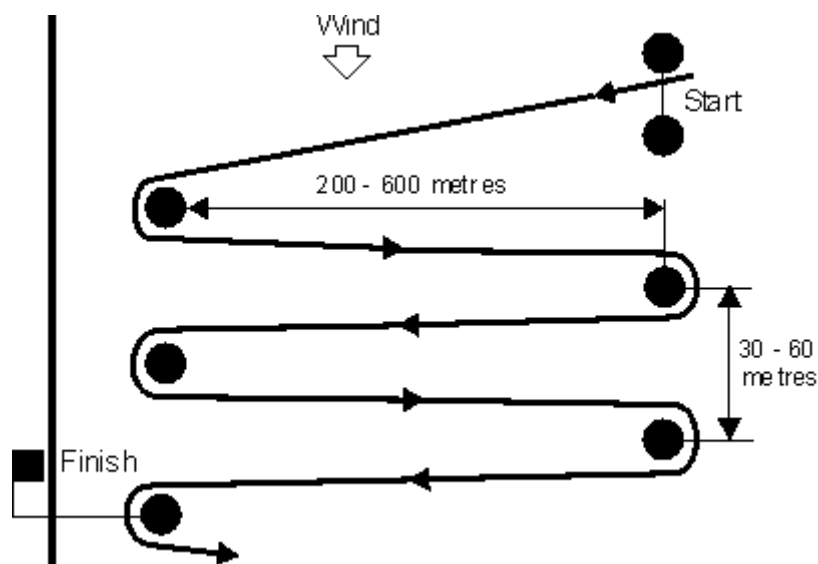

Note: if the start is on or near the beach, the first mark should be where the start is shown on the diagram. The finishing line should be set at such an angle that it can be crossed while sailing on the course from the last mark.

Course for Speed

Standard Offshore Speed Course

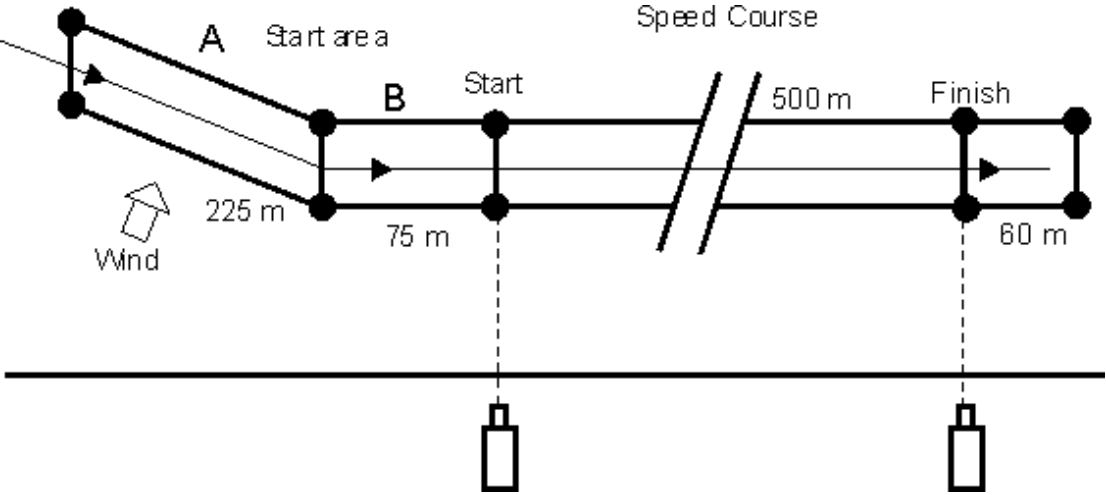

ADDENDUM B

KITEBOARDS PROVIDED BY THE ORGANIZING AUTHORITY

The following sailing instruction is recommended when all kiteboards will be provided by the organizing authority. It can be changed to suit the circumstances. When used, it should be inserted after instruction 3.

4 KITEBOARDS

- 4.1** Kiteboards will be provided for all competitors, who shall not modify them or cause them to be modified in any way except that
- (a) delete
 - (b) delete
 - (c) hulls, kite, lines and control bar may be cleaned, but only with water;
 - (d) adhesive tape may be used anywhere above the water line; and
 - (e) all fittings or equipment designed to be adjusted may be adjusted, provided that the class rules are complied with.
- 4.2** All equipment provided with the kiteboard for sailing purposes shall be in the kiteboard while afloat.
- 4.3** The penalty for not complying with one of the above instructions will be disqualification from all races sailed in which the instruction was broken.
- 4.4** Competitors shall report any damage or loss of equipment, however slight, to the organizing authority's representative immediately after securing the boat ashore. The penalty for breaking this instruction, unless the [protest committee] [jury] is satisfied that the competitor made a determined effort to comply, will be disqualification from the race most recently sailed.
- 4.5** Class rules requiring competitors to be members of the class association will not apply.

APPENDIX M

RECOMMENDATIONS FOR PROTEST COMMITTEES

This appendix is advisory only; in some circumstances changing these procedures may be advisable. It is addressed primarily to protest committee chairmen but may also help judges, protest committee, secretaries, race committees and others connected with protest and redress hearings. Appendix M, is available on the ISAF website (www.sailing.org).

APPENDIX N

INTERNATIONAL JURIES

See rules 70.5 and 91(b). This appendix shall not be changed by sailing instructions or national prescriptions. Appendix N, is available on the ISAF website (www.sailing.org).

Addendum T JUDGING GUIDELINES

THIS SIDE FOR PROTEST COMMITTEE USE

Number Heard together with numbers

Fill in and tick as appropriate

Withdrawal requested Signature Withdrawal permitted

Class Fleet Race Protest time limit

Protest, or request for redress or reopening, received within time limit Time limit extended

Protestor, or party requesting redress or reopening, represented by

Other party, or board being considered for redress, represented by

Names of witnesses

Interpreters

- | | Remarks |
|---|---------------------------|
| No objection about interested party <input type="checkbox"/> | |
| Written protest or request identifies incident <input type="checkbox"/> | |
| 'Protest' hailed at first reasonable opportunity <input type="checkbox"/> | |
| No hail needed; protestee informed at first reasonable opportunity <input type="checkbox"/> | |
| Red flag conspicuously displayed at first reasonable opportunity <input type="checkbox"/> | Not applicable to a board |

Protest or request valid; hearing will continue Protest or request invalid; hearing is closed

FACTS FOUND
.....
.....
.....
.....
.....
.....
.....
.....
.....
.....

Diagram of board is endorsed by committee Committee's diagram is attached

CONCLUSIONS AND RULES THAT APPLY

DECISION

Protest: dismissed Board(s) is (are) disqualified from race(s)
penalized as follows :

Redress: not given given as follows :

Request to reopen a hearing: denied granted

Protest committee chairman and other members
.....

Chairman's signature Date and time

KITEBOARDING SCORING ADJUSTMENT FORM

One penalty – please tick

or

More penalties – please put the number

Date: _____

daily Race No. : _____

Event / Class: _____

total Race No. : _____

Name of
Helm: _____

I declare having taken the above ticked scoring penalty

Identification(s) of the other Kiteboard(s) involved in the incident:

RRS 31.2(Hold on to a Mark)

on Leg: _____

at Mark No: _____

Witness(es): _____

Comments: _____

Signature: _____

Internal use

Received at: _____ :

Sign: _____